

R

**TECHNICAL MANUAL**

**GEIGER COUNTER**

**MODEL E-520**

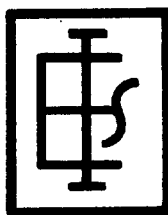

**EBERLINE**  
**Instrument Corporation**  
SANTA FE                      NEW MEXICO

**TECHNICAL MANUAL**

**GEIGER COUNTER**

**MODEL E-520**

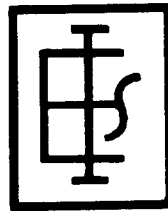

**EBERLINE**  
**Instrument Corporation**  
SANTA FE                      NEW MEXICO

**LIST OF EFFECTIVE PAGES**

Insert latest revised pages; dispose of superseded pages.

NOTE: On a revised page, the portion of the text affected by the latest change is indicated by a vertical line in the outer margin of the page.

TOTAL NUMBER OF PAGES IN THIS MANUAL IS 18, CONSISTING OF THE FOLLOWING:

<u>Page No.</u>	<u>Change in Effect</u>	<u>Latest Publication</u>
Title	Original	June 15, 1970
A	Original	June 15, 1970
i, ii	Original	June 15, 1970
1 thru 14	Original	June 15, 1970

Pages 8 and 10 are blank.

MODEL E-520

TABLE OF CONTENTS

Section	Page
I GENERAL	
Purpose and Description . . . . .	1
Specifications . . . . .	1
II OPERATION	
Description of Controls and Connectors . . . . .	5
Preparation for Use . . . . .	5
Using the Instrument . . . . .	5
III THEORY OF OPERATION	
General . . . . .	7
Functional Theory . . . . .	7
IV MAINTENANCE	
Disassembly and Reassembly . . . . .	9
Preventive Maintenance . . . . .	9
Calibration . . . . .	9
V PARTS LIST	11
VI DIAGRAMS	13

LIST OF ILLUSTRATIONS

Section	Page
1-1 Model E-520 (Shown with SK-1 Speaker) . . . . .	ii
1-2 Typical Energy Response of HP-177B Hand Probe . . . . .	3
1-3 Typical Energy Response of Internal Geiger Tube . . . . .	3
2-1 Location of Controls . . . . .	4
3-1 System Block Diagram . . . . .	6
6-1 General Schematic of the Model E-520 . . . . .	13
6-2 Component Layout . . . . .	14

MODEL E-520

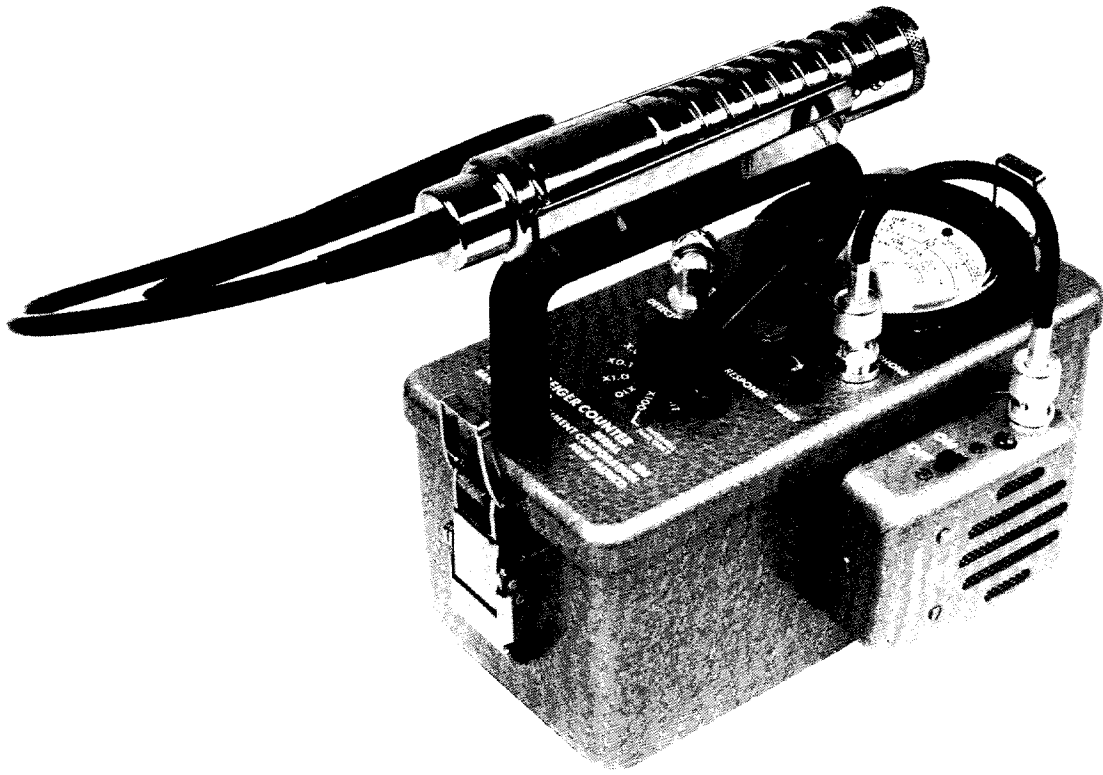

*Figure 1-1. Model E-520 (Shown with SK-1 Speaker)*

## SECTION I GENERAL

### A. PURPOSE AND DESCRIPTION

The Model E-520 Portable Geiger Counter combines the reliability of geiger detectors with new electronic circuits to provide an instrument with outstanding operational characteristics in a small, lightweight package at an economical price. The large, ruggedized meter provides exceptional readability and linearity with a variable response time. Special circuitry yields detector saturation greater than 1000 R/hr. Calibration stability results from temperature compensation and battery voltage regulation. High efficiency circuits extend the life of the two D cell batteries. A rotary switch combines the functions of power switch, battery check and selection of one of the five sensitivity ranges. The amplifier driven phone output may be used with headset, Speaker Assembly (SK-1) or external pulse counter.

To obtain 5 ranges ( 0-0.2, 0-2, 0-20, 0-200, and 0-2000 mR/hr) two different detector tubes are utilized, one being located within the case itself for detection of high level gamma radiation in a range of 0 to 2000 mR/hr. A tube sensitive to lower level gamma and beta radiation is located in the hand probe used on the four lower ranges. Discrimination between beta and gamma radiation is made by means of a rotary shield on the probe. Both mR/hr (closed shield) and CPM (open shield) are presented on the meter scale.

Design features include: Pulse amplifier, monolithic integrated circuit trigger, meter driver with variable response time, phone driver, regulated and feedback controlled high voltage supply, and individual calibration controls for each range. A single printed circuit board holds and interconnects all components resulting in a minimum number of solder joints which enhances reliability. The printed circuit board connects to the die cast cover, forming a completely operational instrument with controls and test points exposed for ease of calibration or maintenance. The instrument is splash proof and dust proof and, with its temperature stability, can be used under almost any weather conditions.

### B. SPECIFICATIONS

#### 1. FRONT PANEL CONTROLS AND CONNECTIONS

a. RANGE switch: Seven positions; OFF, BATT. CHECK, X.01, X.1, X1, X10 and X100.

b. Meter: Ruggedized, waterproof, 0-20 micro-amperes.

c. RESPONSE control.

d. RESET switch

e. PHONE connector.

f. DETECTOR connector.

#### 2. READOUT

a. Range: 5 linear ranges, switch controlled: 0.2, 2.0, 20, 200 and 2000 mR/hr full scale.

b. Meter Scale: 0-20 mR/hr shield closed and 0-28K CPM shield open. BATT. OK limits marked on meter face.

c. Linearity: 0-0.2, 0-2, 0-20 mR/hr ranges,  $\pm 8\%$  of full scale nominal. 0-200 mR/hr range  $\pm 15\%$  of full scale nominal. 0-2000 mR/hr  $\pm 10\%$  of full scale nominal.

d. Response Time: Variable by panel control from 10 seconds to 2 seconds to 90% of final value.

e. Phone: One pulse for each event counted. Negative pulse approximately 2.5 volts in amplitude, pulse width determined by range switch position.

f. Saturation Level: Meter will remain at full scale on all ranges in a field of 1000 R/hr.

g. Voltage Coefficient: Reading changes less than 10% with battery voltage from 3.0 to 2.0 volts (new batteries to end point).

#### 3. DETECTORS

a. Internal: Small, rugged, halogen quenched. Cadmium shield surrounding tube for low energy compensation. Sensitivity approximately 100 CPM per mR/hr for  $^{137}\text{Cs}$ .

b. External Probe: (Model HP-177B)

(1) GM Tube: Thin wall (30 mg/cm<sup>2</sup>) halogen quenched.

MODEL E-520

(2) Housing: Rotating beta shield 1/16 in. thick chrome plated brass.

(3) Environmental: Temperature Range -55°C to 75°C, waterproof.

(4) Sensitivity: Approximately 1200 CPM per mR/hr for <sup>137</sup>Cs.

(5) Cable: Approximately 3 ft. long integrally attached to probe.

c. Energy Response: See figures 1-2 and 1-3.

4. POWER SUPPLY

a. Batteries: Two D size cells held by internal captive holders.

b. Voltage Requirement: 1.6 maximum to 1.0 minimum volts per cell.

c. Life: Variable depending on cell type, age, temperature, etc. Nominal life with new cells at room temperature for each type is:

Carbon-zinc	300 hours
Alkaline	500 hours
Mercury	700 hours
Nickel-Cadmium (single charge)	200 hours

5. ENVIRONMENTAL

a. Weather: Splash proof by use of O-ring seals throughout.

b. Temperature: The instrument is operational from -40°F to +140°F with a typical temperature coefficient of reading less than 0.1% per °F.

The battery type used limits the low temperature performance because of terminal voltage decrease and internal impedance increase. For prolonged operation at low temperatures the following criteria is suggested:

BATTERY TYPE	USE TO
Mercury	+32°F (0°C)
Carbon-zinc	0°F (-18°C)
Alkaline	-40°F (-40°C)
Nickel-Cadmium	-40°F (-40°C)

6. MECHANICAL

a. Dimensions: Approximately 4 in. wide by 8 in. long by 7-3/4 in. high including handle.

b. Weight: Approximately 4-3/8 lbs. including carbon-zinc batteries and HP-177B probe.

MODEL E-520

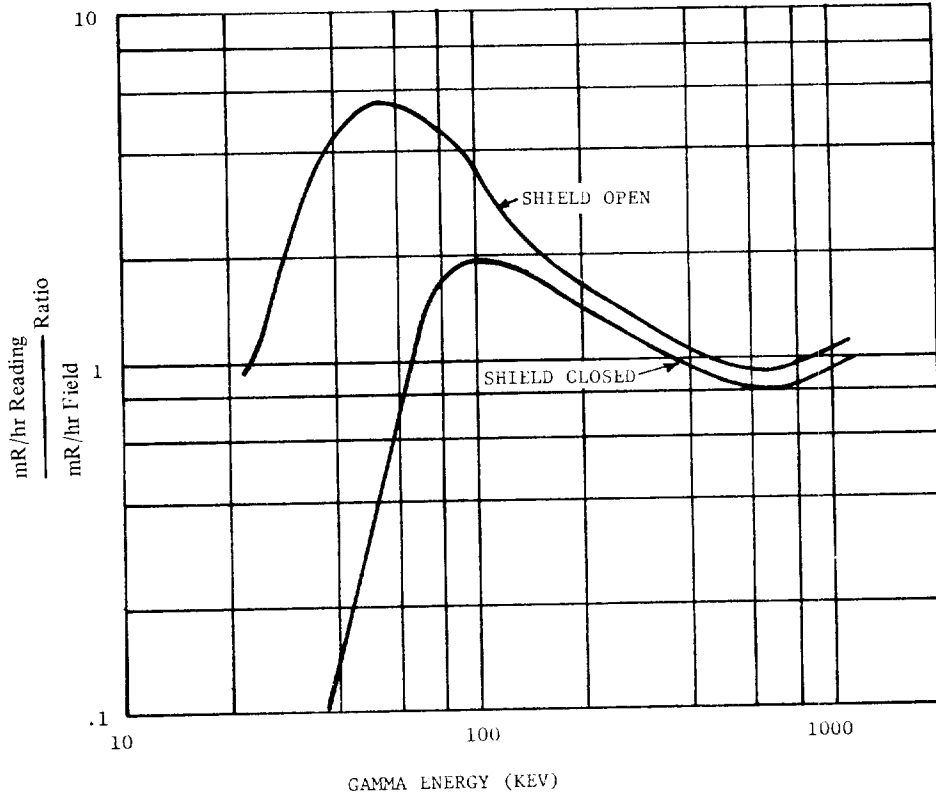

Figure 1-2. Typical Energy Response of HP-177B Hand Probe

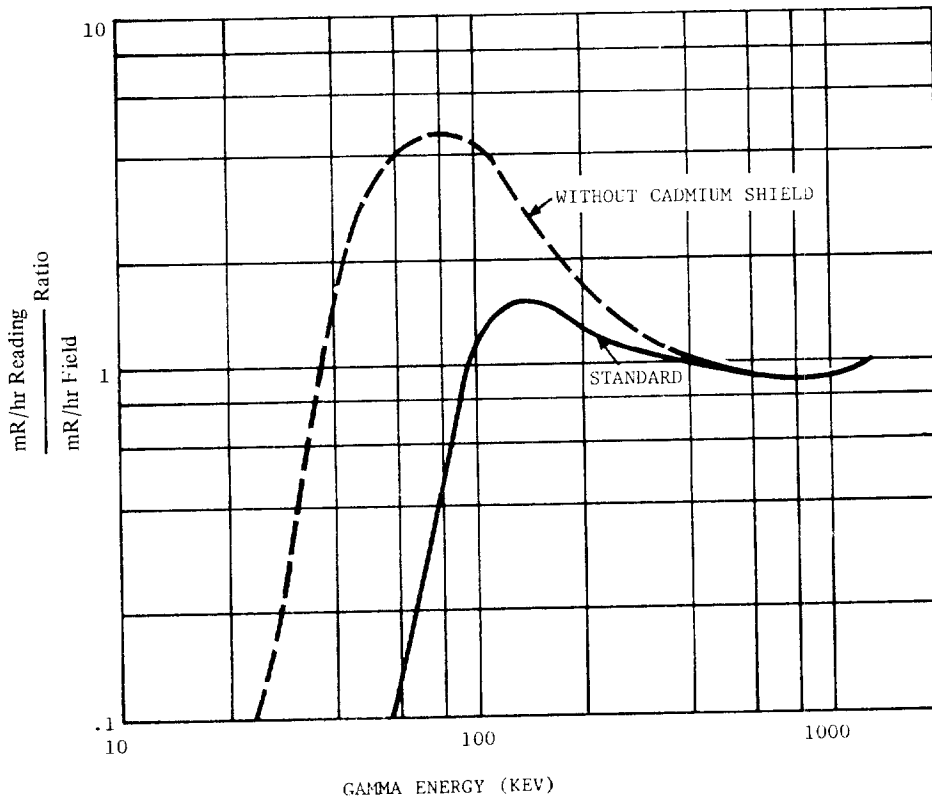

Figure 1-3. Typical Energy Response of Internal Geiger Tube

MODEL E-520

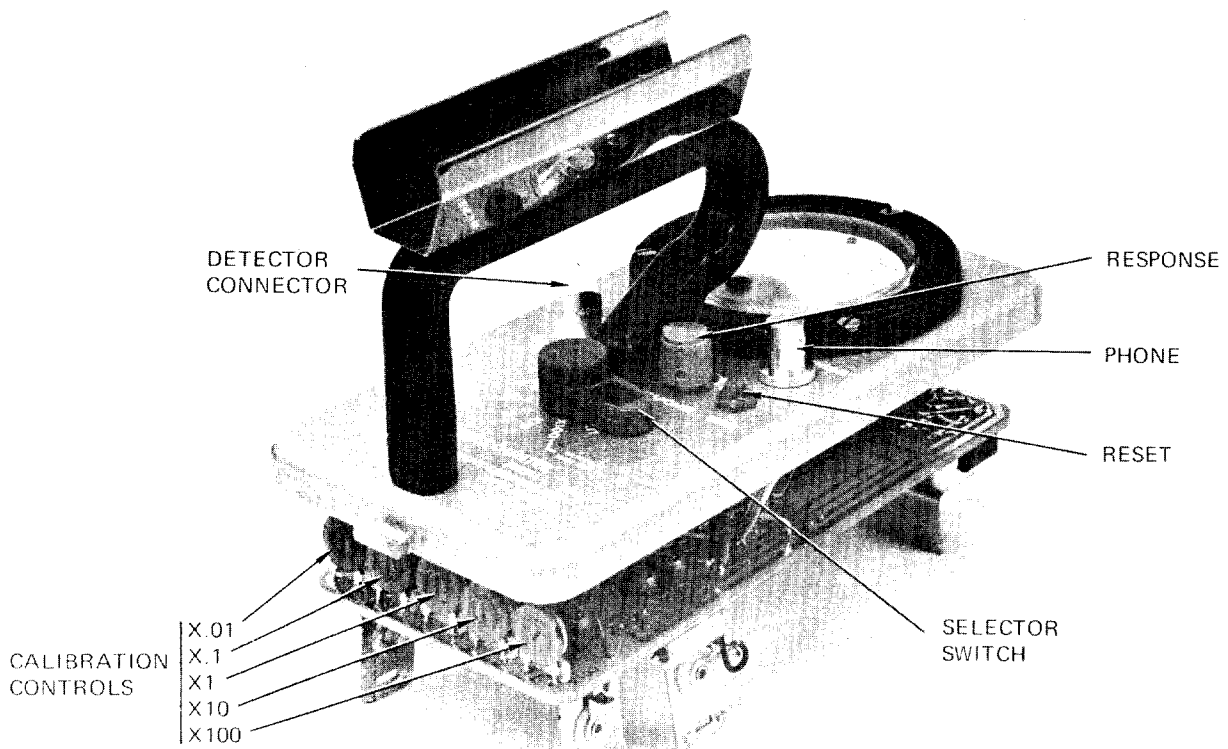

Figure 2-1. Location of Controls

## SECTION II OPERATION

### A. DESCRIPTION OF CONTROLS AND CONNECTORS

#### 1. EXTERNAL (See figure 2-1)

a. **Switch:** Seven position rotary switch that turns instrument OFF, checks BATTERY condition and selects scale multipliers of X.01, X0.1, X1.0, X10 and X100. This number must be multiplied by the meter indication to obtain the proper reading.

b. **RESPONSE:** Controls response time of meter to the most desirable compromise between speed and fluctuation for the particular usage.

c. **RESET:** Discharges integrating capacitor, bringing meter reading to zero rapidly.

d. **PHONE:** Pulse output for use with earphone, speaker or external scaler. Mating connector is BNC series coaxial.

e. **DETECTOR:** Connection to hand probe. BNC series coaxial.

#### 2. INTERNAL (See figure 2-1)

a. **Calibration Controls:** One control for each range which individually calibrates that range to agree with the input pulse rate.

### B. PREPARATION FOR USE

#### 1. INSPECTIONS

The instrument should be checked for physical damage.

### 2. CONNECTIONS

Connect the probe cable to the probe connector.

### C. USING THE INSTRUMENT

#### 1. STARTING

Turn the switch to the BATTERY check position. The meter should indicate within the BATT OK area.

#### 2. OPERATION CHECK

Place a check source in a repeatable position adjacent to the detector and move the switch to a range that gives an upscale reading. Note that the reading is sensitive to the position of the source. The reading may be recorded for future reference.

Push the RESET button and the reading should drop to zero rapidly, then climb back to source reading when the RESET is released. The RESPONSE may be adjusted to get the most desirable compromise between speed of response and meter fluctuation.

#### 3. INTERPRETATION OF INDICATIONS

The meter reading must be multiplied by the scale factor to obtain the proper number. The fluctuation of the meter is normal and is caused by the random nature of radioactive decay.

MODEL E-520

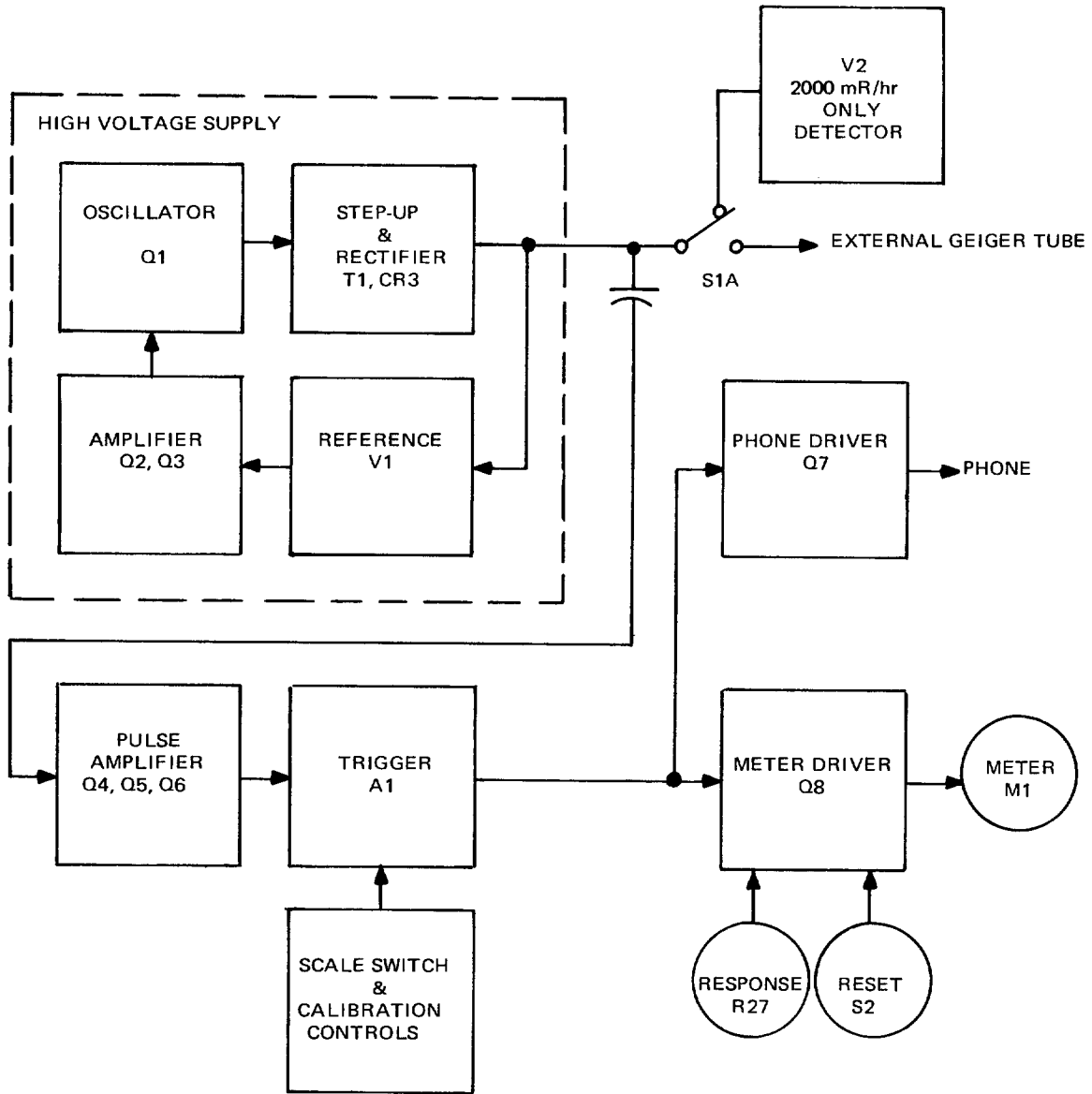

Figure 3-1. System Block Diagram

## SECTION III

### THEORY OF OPERATION

#### A. GENERAL

The high voltage supply develops +900 volts, which is applied to the geiger tube, giving it the proper operating voltage. When radiation reacts in the geiger tube, negative pulses are generated. These pulses are coupled into the amplifier where they are amplified. They are then coupled to the trigger circuit where they are converted to standard size pulses of power. These standard pulses are applied to the meter driver which converts them to standard pulses of current, averages this current and drives the meter. Thus the meter deflection is proportional to the average rate of radiation at the geiger tube.

#### B. FUNCTIONAL THEORY (See figures 3-1 and 6-1)

##### 1. HIGH VOLTAGE SUPPLY

The oscillator transistor (Q1) drives T1 primary and gets its feedback from T1's red-orange winding. The voltage is stepped up by T1's secondary, rectified, filtered and applied to V1. V1 regulates at 900 volts. The current through V1 is sensed by Q2, amplified, and used to control the current through Q3. The current through Q3 controls the bias level of the oscillator Q1. This tends to hold the current through V1 to a constant value regardless of battery voltage. The result of this is that power is not wasted with new batteries, just so it will function with lower voltage batteries. This greatly extends battery life.

##### 2. AMPLIFIER

Q4 and Q5 form a feedback controlled preamplifier which amplifies the negative pulses from the detector. The feedback enhances stability and the biasing on Q4 protects from overdrive. Q6 is biased just into cut-off so its output is near 0 volts. A pulse turns it on and the resulting positive output pulse starts the trigger circuit.

##### 3. TRIGGER

Integrated circuit A1 is connected to operate as a mono-stable multivibrator whose pulse width is controlled by the RC time constant between its pins 7 and 5. This time constant is established by the setting of S1D (scale selection) which selects a particular R and C. The calibration controls form the R for each scale, making the pulse width continuously adjustable for calibration.

When the trigger is initiated by the pulse from Q6 the output at pin 6 goes positive and holds until the predetermined time (RC) elapses.

##### 4. METER DRIVER

The driver Q8 is normally off, so no current flows through M1. When the trigger is on, Q8 is turned on and current flows. The amount of current is determined by the voltage on the base of Q8 and R25. The length of time that current flows is determined by the pulse width of the trigger. This (current times time) forms a certain charge which is transferred to C10 for each event counted. C10 discharges through M1, yielding a certain average current dependent on the rate of input pulses. Changing the pulse width of the trigger (i.e., changing scales or calibration pot setting) changes the average current for a given input pulse rate. This allows the meter to be calibrated to read in CPM or mR/hr at the detector.

The response time of M1 is controlled by the RC time constant of C10 and R27, the response control. With R27 set to low resistance the time constant is fast, and at high resistance it is slow.

##### 5. PHONE DRIVER

Q7 amplifies and inverts the output pulse from the trigger, yielding a large amplitude negative going pulse which is capacitively coupled to the PHONE connector.

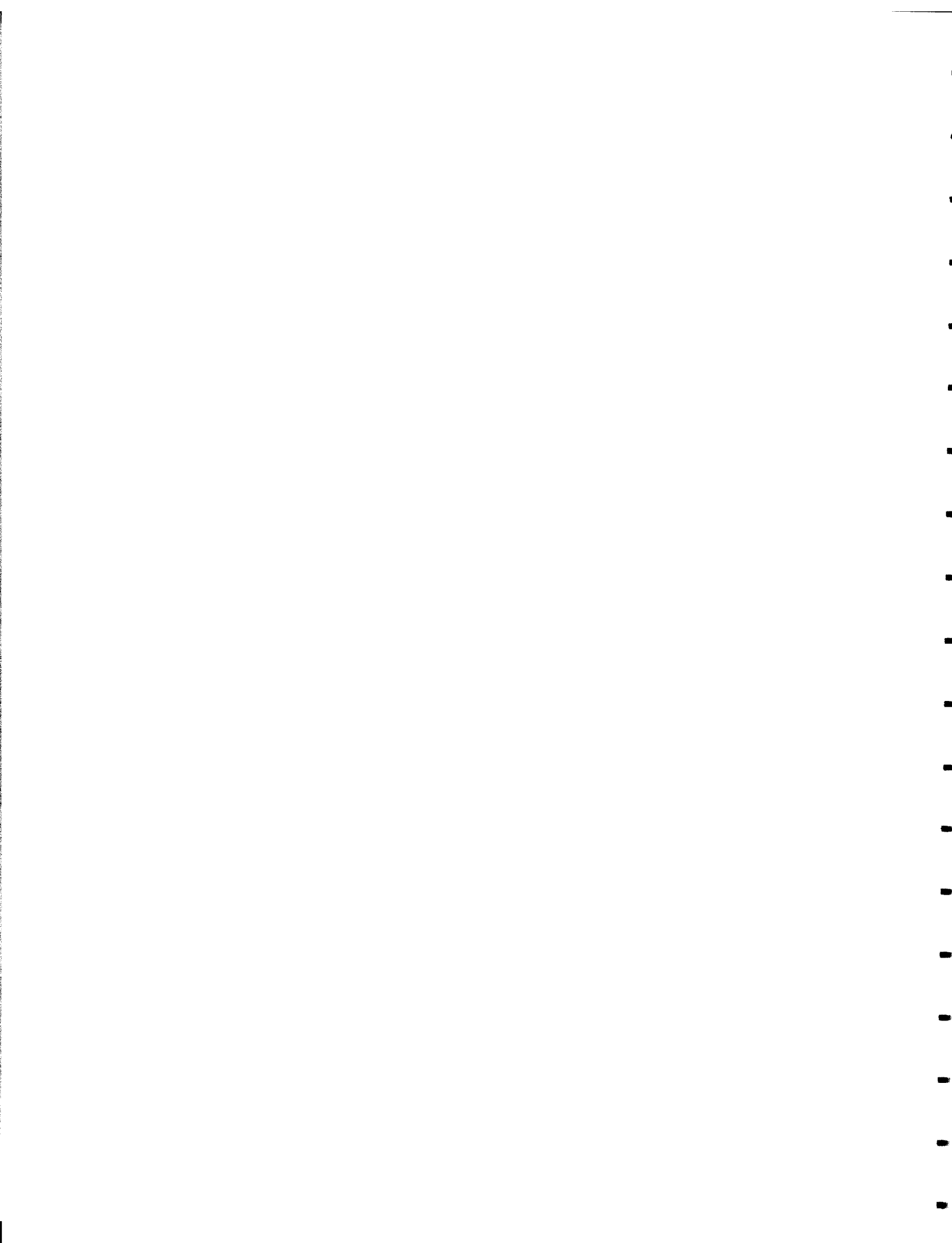

## SECTION IV MAINTENANCE

### A. DISASSEMBLY AND REASSEMBLY

#### 1. BATTERIES

The batteries are secured in captive holders on the etched board. The holding straps may be removed by hand, but a small screwdriver facilitates removal. Pull the batteries from the holders. Replace by sliding batteries into holders, making certain they are centered and of the correct polarity. Replace holding straps.

#### 2. ETCHED BOARD

The etched board and cover may be separated for troubleshooting. Proceed as follows:

- a. Remove batteries to prevent electrical damage during disassembly.
- b. Remove knob and mounting nut from scale switch.
- c. Remove 2 screws that secure meter to circuit board.
- d. Separate board and cover without putting undue stress on wires.
- e. For troubleshooting, place jumpers from meter studs to corresponding points on board and replace batteries.
- f. Reassemble in reverse order of disassembly.

### B. PREVENTIVE MAINTENANCE

1. Keep the instrument clean and dry.
2. Replace batteries when their check reading is below the acceptable level.

3. Remove batteries if the instrument is to be inactive for a long period.

### C. CALIBRATION

For maximum accuracy, the instrument should be calibrated under the same conditions as it will be used. Refer to section IB, 2 g and 5 b for effects of battery voltage and temperature.

The instrument can be calibrated to either counts per minute or mR/hr on all ranges except the X100 (internal tube) range which must be calibrated to mR/hr only.

1. Place the detector in a gamma radiation field equal to about 3/4 scale on the meter.
2. Adjust the calibration control for the range selected until meter reading agrees with radiation field.
3. Repeat for each scale (X.01, X0.1, X1.0 and X100).

To calibrate to counts per minute, proceed as follows:

1. Capacitively couple a pulse generator into the detector connector using a capacitor with a 1 KV or higher voltage rating. The pulse generator must have a negative pulse greater than 15 mV amplitude and a frequency range covering the instrument range.
2. Adjust pulse generator frequency to correspond with approximately 3/4 scale meter reading and adjust the calibration control for the range selected until meter reading agrees with the frequency.
3. Repeat for all ranges except X100 (internal tube).

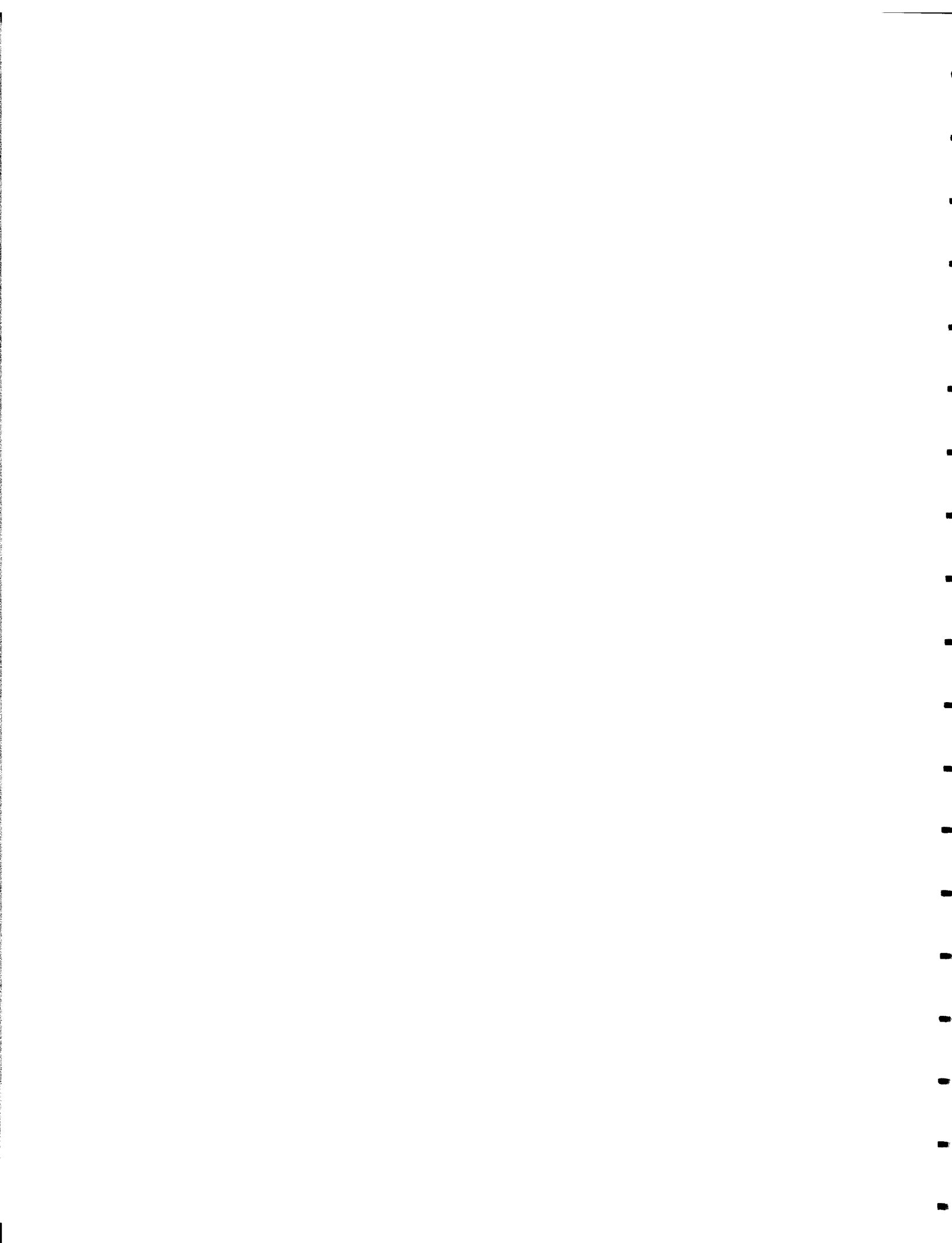

**SECTION V**  
**PARTS LIST**

REF DESIG	PART	DESCRIPTION	MFR AND PART NO
A1	IC	RTL Dual Gate, Milliwatt	Fairchild U5B991029X or Motorola MC710G or NSC NC3010
BT1, BT2	Battery	Carbon-zinc, D size	Eveready 1050 or equiv.
C1	Capacitor	330 $\pm$ 20%, 6V	Kemet K3300C6
C2	Capacitor	.047 $\pm$ 20% MFD, 50BV	GE 75F1R5A 473
C3, C5, C11	Capacitor	.01, MFD, 2KV	Sprague BL-S10
C4, C9	Capacitor	3.3 $\pm$ 20%, MFD, 10V	Kemet K3R3C10
C6	Capacitor	.01, 200V $\pm$ 10%	Sprague 192P-10392
C7, C8	Capacitor	.001 200V, $\pm$ 10%	Sprague 192P-10292
C10	Capacitor	120 MFD, 10V	Dickson CS13B-C127M
C12, C13	Capacitor	.0018, 200V, $\pm$ 10%	Sprague 192P-18292
C14	Capacitor	.018, $\pm$ 10%, MFD, 80V	Sprague 192P-1839R8
C15	Capacitor	.18, $\pm$ 10%, MFD, 80V	Sprague 192P-1849R8
C16	Capacitor	1.8, $\pm$ 10%, MFD, 20V	Mallory CS13-BE185K
CR1, CR2	Diode		1N456A
CR3	Diode	2500 PIV	Varo VA-25
CR4	Diode		1N914
J1	Connector Jack	BNC (Phone)	UG-657/U
J2	Connector	BNC (Detector)	UG-1098/U
M1	Meter	0-20ua, DC with 10472- B26 face	Triplett 321-HR
Q1	Transistor	PNP	2N404
Q2, Q3, Q4, Q5	Transistor	NPN, Silicon	2N4124
Q7, Q8			
Q6	Transistor	PNP, Silicon	2N4126
R1, R2	Resistor	270, $\pm$ 10%, 1/4W	
R3	Resistor	22 Mego, $\pm$ 10%, 1/2W	
R4	Resistor	1 Mego, $\pm$ 10%, 1/4W	
R5	Resistor	470K, $\pm$ 10%, 1/4W	
R6	Resistor	330, $\pm$ 10%, 1/4W	
R7, R24	Resistor	1K, $\pm$ 10%, 1/4W	
R8	Resistor	8.2K, $\pm$ 10%, 1/4W	
R9	Resistor	15K, $\pm$ 10%, 1/4W	
R10	Resistor	3.9K, $\pm$ 10%, 1/4W	
R11	Resistor	3K, $\pm$ 10%, 1/4W	
R12, R13	Resistor	6.2K, $\pm$ 5%, 1/4W	
R14	Resistor	24K, $\pm$ 10%, 1/4W	
R15	Resistor	27K, $\pm$ 10%, 1/4W	

MODEL E-520

REF DESIG	PART	DESCRIPTION	MFR AND PART NO
R16	Resistor	2.2K, $\pm 10\%$ , 1/4W	CST type x Ht201R103B, RR9167
R17	Resistor	2.7K, $\pm 10\%$ , 1/4W	
R18,R19,R20	Potentiometer	10K	
R21,R22			
R23	Resistor	10K, $\pm 10\%$ , 1/4W	
R25	Resistor	220, $\pm 10\%$ , 1/4W	
R26	Resistor	180K, $\pm 5\%$ , 1/4W	
R27	Potentiometer (Response)	25K, $\pm 10\%$ , 1/4W	
RT1	Sensistor	10K at 25°C $\pm 10\%$	
S1	Switch (scale)		
S2	Switch(Reset)		
T1	Transformer		EIC 10557-B05 Micro Switch 1PB5
V1	Regulator Tube	900V, $\pm 2\%$ , T-3	Microtran M-8050
V2	Geiger Tube	900V	
			Victoreen 5841 LND 726

SECTION VI  
DIAGRAMS

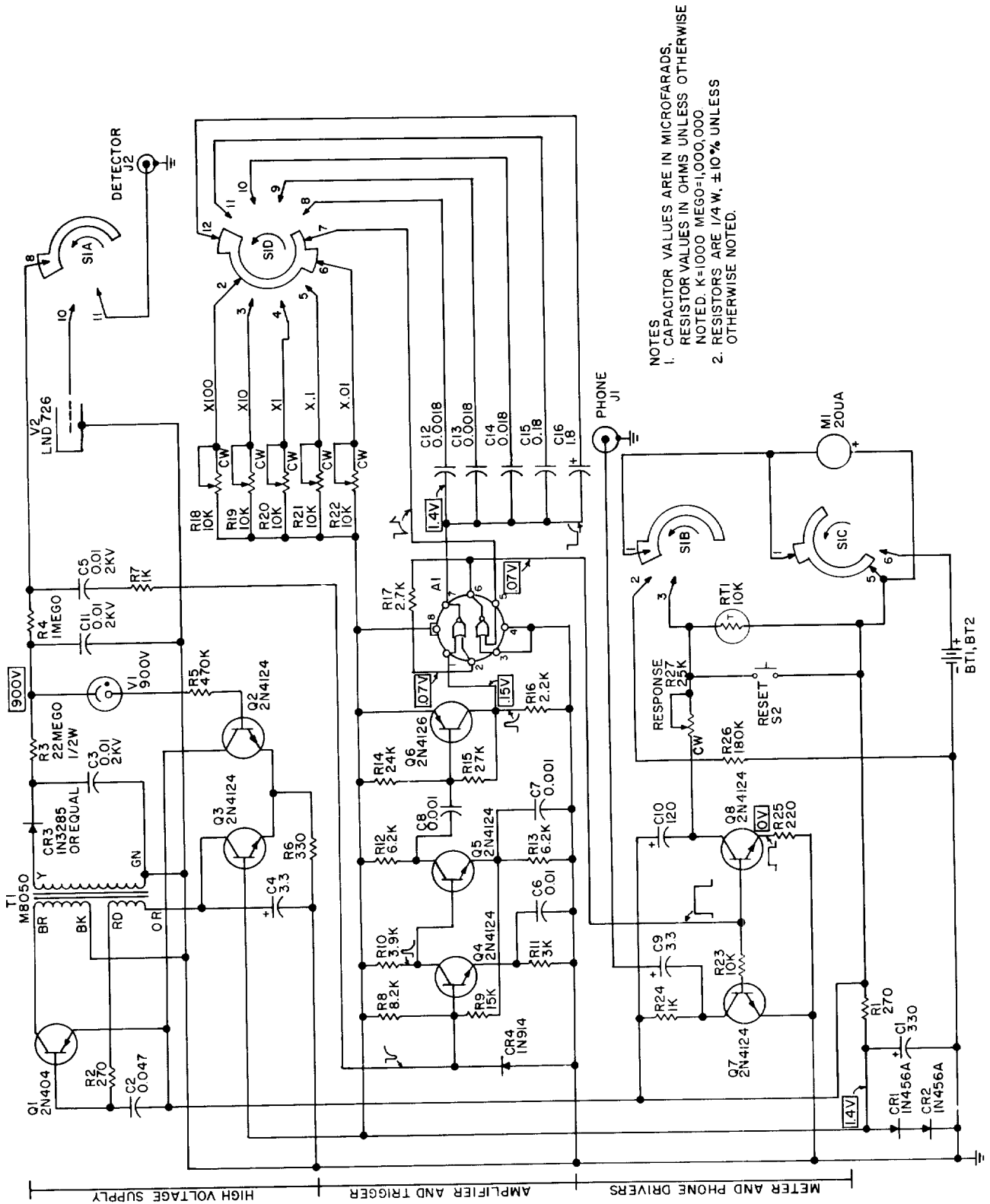

NOTES  
1. CAPACITOR VALUES ARE IN MICROFARADS.  
RESISTOR VALUES IN OHMS UNLESS OTHERWISE NOTED. K=1000 MEGO=1,000,000.  
2. RESISTORS ARE 1/4W, ±10% UNLESS OTHERWISE NOTED.

Figure 6-1. General Schematic of the Model E-520

MODEL E-520

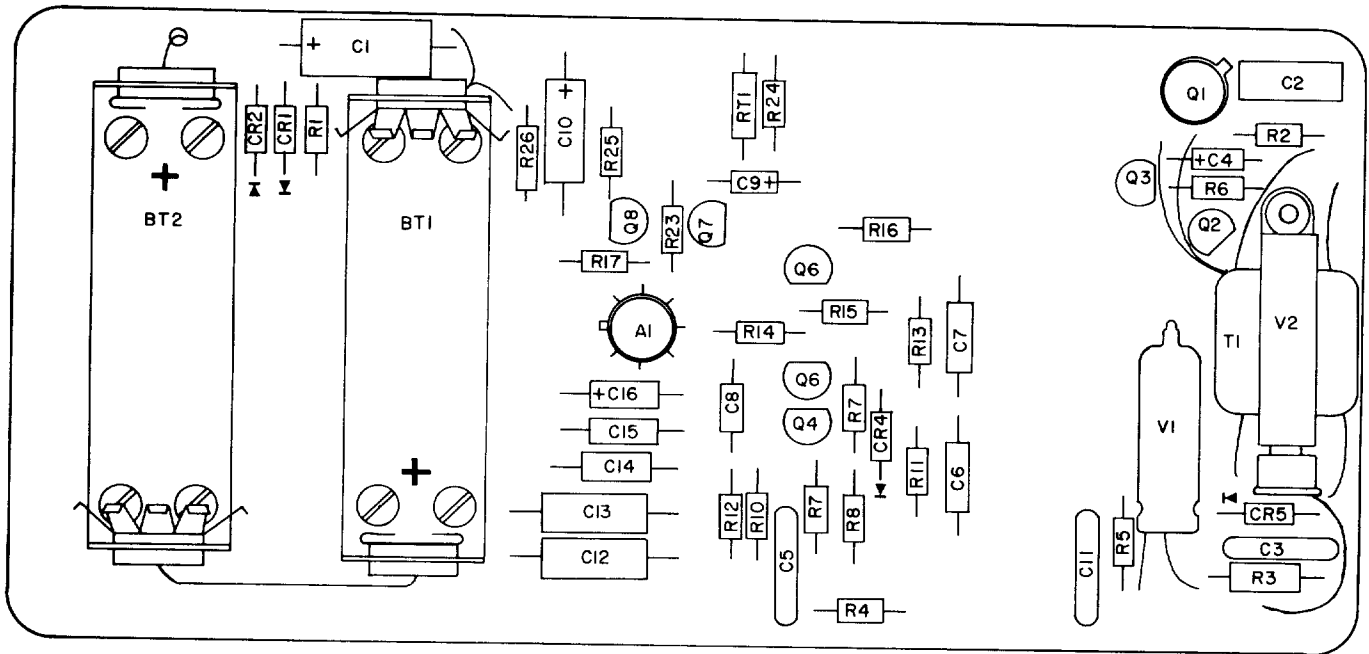

Figure 6-2. Component Layout