

One Book / One Caliber

*The
Complete
Reloading
Manual
for the
10mm
.40 S & W*



Containing Unabridged Information
from U.S. Bullet
and Powder Makers

*Accurate * Alliant * Hodgdon * Hornady
IMR * Lyman * Nosler * RCBS * Scot
Sierra * Speer * Winchester and Others*

**2,788 Proven & Tested Loads
148 Various Bullet Designs
63 Different Powders**

RELOADING SAFETY RULES

Reloading is an enjoyable and rewarding hobby that is easily conducted with safety. But, like many other human endeavors carelessness or negligence can make reloading hazardous.

The essence of reloading safety is proper handling and storage of primers and powder. By observing the following rules, the chance of hazardous occurrence becomes extremely remote.

Store powder and primers beyond the reach of children and away from heat and open flames. Do not smoke when reloading.

Keep no more powder than needed in an open container. Immediately return unused powder to its original factory container.

Don't use any powder unless its identity is positively known. Scrap all mixed powders and those of uncertain or unknown identity.

Do not store primers in bulk. To do so is to create a bomb! Bulk primers will mass detonate. Do not use primers when their identity is lost. Safely dispose of unknown types of primers.

Courtesy of Speer Reloading Manual No. 11

All loading data contained in this book is the result of testing by the various bullet and powder manufacturers. Under carefully controlled conditions and with the components and test equipment specified, this data proved safe in their tests. Since none of the companies, nor the publisher, listed herein has control over the components and equipment which may be used with this published information, no responsibility is implied or assumed for results obtained through its use.

Courtesy of Hornady Manufacturing Company, Inc.

Sierra Bullets cannot and does not accept any liability, either expressed or implied, for results of damage or injury arising from or alleged to have arisen from the use of the data in this manual.

Courtesy of Sierra Bullets

Follow loading recommendations exactly. Don't substitute components for those listed. Start loading with the minimum powder charges. Understand what you are doing and why it must be done in a specific way. Stay alert when reloading. Don't reload when distracted, disturbed or tired.

Courtesy of Nosler Bullets, Inc.

The Complete Reloading Manual for the 10mm/.41 Autos

The publisher is deeply indebted to the following companies for their permission to reprint their proprietary reloading information in this manual.

**Accurate Arms Company, Inc.
Blount, Inc.
Alliant Technologies
Hodgdon Powder Co., Inc.
Hornady Manufacturing Company
IMR Powder Company
Lyman Products, Inc.
Nosler Bullets, Inc.
RCBS Bullets
Sierra Bullets, L.P.
Scot Powder Company
Speer Bullets
Winchester**

Copyright 2004 by Loadbooks USA, Inc., P.O. Box 129, Acton, CA 93510
Phone/Fax: 661/269-8991
Printed in the United States of America. All Rights Reserved.

TABLE OF CONTENTS

10MM AUTO/.40 S&W/.41 AE

10MM AUTO

HORNADY BULLETS

Hornady Introduction	1
Hornady 155 grain	2
Hornady 180 grain	3
Hornady 200 grain	4
Hornady 180 grain (Lead)	5

NOSLER BULLETS

Nosler Introduction	6
Nosler 135 grain	8
Nosler 150 grain	9
Nosler 170 grain	10
Nosler 180 grain	11

SIERRA BULLETS

Sierra Introduction	12
Sierra 135/150 grain	13
Sierra 165 grain	14
Sierra 180 grain	15
Sierra 190 grain	16

SPEER BULLETS

Speer Introduction	17
Speer 155 grain	18
Speer 180/200 grain	19

LYMAN BULLETS

Lyman Introduction	20
Lyman 175 grain	23
Lyman 200 grain	24

TABLE OF CONTENTS

10MM AUTO/.40 S&W/.41 AE

10MM AUTO

ACCURATE ARMS POWDERS

Accurate Introduction	25
Handgun Loads	26

ALLIANT POWDERS

135-155 grain Loads.....	29
170-200 grain Loads.....	30

HODGDON POWDERS

Hodgdon Introduction.....	31
135-200 grain Loads.....	32

IMR POWDERS

800X/SR4756/SR7625	33
--------------------------	----

SCOT POWDERS

Royal Scot/Pearl Scot/Solo 1000.....	34
Solo 1250/Solo 1500	35

WINCHESTER POWDERS

150-200 grain Loads.....	36
--------------------------	----

VIHTAVUORI POWDERS

Vihtavuori Introduction	37
155-200 grain Loads.....	38

TABLE OF CONTENTS

10MM AUTO/.40 S&W/.41 AE

40 S & W

HORNADY BULLETS

Hornady Introduction	39
Hornady 155 grain	40
Hornady 180/200 grain	41
Hornady 180 grain (Lead).....	42

NOSLER BULLETS

Nosler Introduction	43
Nosler 135 grain	45
Nosler 150 grain	46
Nosler 170 grain	47
Nosler 180 grain	48

SIERRA BULLETS

Sierra Introduction	49
Sierra 135 grain	50
Sierra 150 grain	51
Sierra 165 grain	52
Sierra 180 grain	53
Sierra 190 grain	54

SPEER BULLETS

Speer Introduction	55
Speer 155 grain	56
Speer 165 grain	57
Speer 180 grain	58

LYMAN BULLETS

Lyman Introduction	59
175 grain	60
200 grain	61

ACCURATE ARMS POWDERS

Handgun Loads	62
---------------------	----

ALLIANT POWDERS

135-200 grain	65
---------------------	----

HODGDON POWDERS

Hodgdon Introduction	66
135-200 grain Loads	67

IMR POWDERS

180-200 grain Loads	68
---------------------------	----

WINCHESTER POWDERS

150-200 grain Loads	69
---------------------------	----

VIHTAVUORI POWDERS

Vihtavuori Introduction	70
150-200 grain Loads	71

TABLE OF CONTENTS

10MM AUTO/.40 S&W/.41 AE

41 ACTION EXPRESS

HORNADY BULLETS

Hornady Introduction	72
Hornady 210 grain.....	73

SIERRA BULLETS

Sierra Introduction.....	74
170/210 grain.....	75

SPEER BULLETS

Speer Introduction	76
Speer 180 grain.....	77

HODGDON POWDERS

Hodgdon Introduction.....	78
170-210 grain Loads.....	79

ACCURATE ARMS POWDERS

See Page 62

10MM MAGNUM

ACCURATE ARMS POWDERS

Handgun Loads.....	80
IAI Loads.....	81

The Hornady Handbook of Cartridge Reloading 5th Ed.

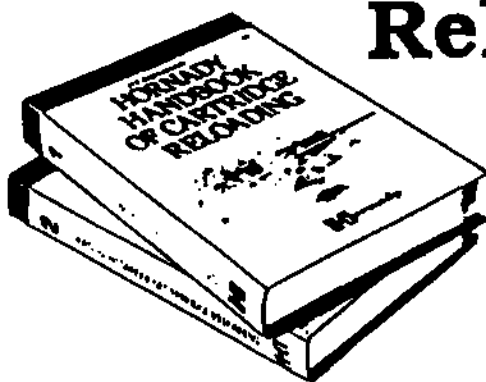

This new two-volume set contains the most up-to-date reloading information available. Volume I contains the loading formulas for all Hornady rifle and pistol bullets. Volume II contains the ballistic tables and charts you need to fine tune your loads.

This two-volume format enables you to have both the loading formulas and ballistics tables open to the same caliber without having to thumb back and forth.

Available at your reloading dealer.

 **Hornady**

OUR REPUTATION RIDES ON EVERY SHOT

Hornady Mfg. Co., Box 1848, Grand Island, NE 68802-1848

**Save time on your
next shot!**



Hornady ONE SHOT Gun Cleaner and Case Lube.

In the field or on the loading bench
Fast drying, non-oily
Cleans and lubes bullets, presses and guns

Hornady

OUR REPUTATION RIDES ON EVERY SHOT

Hornady Mfg. Co., Box 1848, Grand Island, NE 68802-1848

10MM AUTO - HORNADY BULLETS

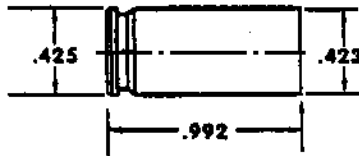

10mm AUTO

HANDGUN: Colt Delta Elite
BARREL: 5", 1 in 16" Twist
CASE: Hornady
PRIMER: Winchester WLP

BULLET DIAMETER: 0.400"
MAXIMUM C.O.L.: 1.260"
MAX. CASE LENGTH: 0.992"
CASE TRIM LENGTH: 0.982"

Venting frustration over the "insufficient" power of such established cartridges as the 9mm Luger, 38 Super, or 45 ACP has led many shooters and wildcatters to take direct action. Believing the answer to this dilemma to be a totally new cartridge, Whit Collins, John Adams, and Irving Stone with the assistance of Jeff Cooper, set out to create one. Using cut-off 30 Remington cases with a 40 caliber 180 grain bullet from the 38-40 Winchester, they created the 10mm Automatic. The Bren Ten was the first production firearm for the new cartridge, but production problems caused the end of the manufacturing plant and the pistol as well.

Colt, however, recognized some potential with the 10mm Auto and started producing a modified M1911, known as the Delta Elite. Several other manufacturers offered firearms in 10mm Auto.

The 10mm Auto appeared in 1989 as the FBI reviewed its sidearm requirements and its prospects looked good. The advent of the 40 S&W changed this perspective. It is unclear whether a massive law enforcement switch to 10mm—or 40 caliber—will occur.

Hornady offers three different bullet weights (155 grain, 180 grain, and the 200 grain) in six different 40 caliber designs. Velocities and energies are impressive as is accuracy. Best overall results were obtained with AA No. 7 in our testing.

10MM AUTO - HORNADY BULLETS

155 GRAIN BULLETS

SECTIONAL DENSITY: 0.138
DIAMETER: 0.400"



#4000 HP/XTP

B.C.: 0.137 C.O.L.: 1.260"

POWDER	VELOCITY (FPS—feet per second)						
	1150	1200	1250	1300	1350	1400	1450
WIN 231	7.1 gr.	7.6 gr.	8.0 gr.				
VHNT N-340	7.3 gr.	7.7 gr.	8.1 gr.				
Unique	7.3 gr.	7.8 gr.	8.4 gr.	8.9 gr.			
Herco	7.8 gr.	8.5 gr.	9.2 gr.	9.9 gr.			
POWER PIST	8.4 gr.	8.8 gr.	9.2 gr.	9.6 gr.	10.0 gr.		
VHNT 3N37	8.4 gr.	8.8 gr.	9.3 gr.				
WIN ACT PIST	8.6 gr.	9.1 gr.	9.5 gr.	10.0 gr.			
BOG X	8.1 gr.	9.0 gr.	9.8 gr.	10.7 gr.	11.5 gr.		
JMR 4750	8.8 gr.	9.3 gr.	9.8 gr.	10.3 gr.	10.9 gr.	11.4 gr.	
HS-6	9.4 gr.	9.9 gr.	10.3 gr.	10.8 gr.	11.2 gr.		
AA No. 5	9.6 gr.	10.1 gr.	10.5 gr.	10.5 gr.	11.0 gr.		
Blue Dot	10.2 gr.	10.7 gr.	11.1 gr.	11.5 gr.	12.0 gr.	12.4 gr.	12.9 gr.
HS-7	10.1 gr.	10.6 gr.	11.2 gr.	11.7 gr.	12.3 gr.		
AA No. 7	11.9 gr.	12.4 gr.	13.0 gr.	13.5 gr.	14.0 gr.	14.6 gr.	15.1 gr.

■ indicates maximum load • use with caution

10MM AUTO - HORNADY BULLETS

180 GRAIN BULLETS

SECTIONAL DENSITY: 0.161
DIAMETER: 0.400"

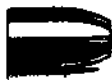

#40040 HP-XTP
B.C.: 0.164 C.O.L.: 1.260"



#400417 FMJ-FP ENC
B.C.: 0.188 C.O.L.: 1.260"

VELOCITY (FPS-feet per second)

POWDER	950	1000	1050	1100	1150	1200	1250
Unique	5.6 gr.	6.2 gr.	6.7 gr.	7.1 gr.			
VHNT N 340	5.9 gr.	6.3 gr.	6.7 gr.	7.1 gr.	7.5 gr.		
WW 231	5.9 gr.	6.3 gr.					
Herco	6.3 gr.	6.8 gr.	7.2 gr.	7.7 gr.	8.2 gr.		
POWER PIST	6.8 gr.	7.2 gr.	7.6 gr.	8.0 gr.	8.4 gr.		
800 X	6.7 gr.	7.3 gr.	7.8 gr.	8.4 gr.	9.0 gr.	9.6 gr.	10.1 gr.
4756	6.8 gr.	7.3 gr.	7.8 gr.	8.3 gr.	8.8 gr.		
VHNT 3 N 37	6.9 gr.	7.3 gr.	7.7 gr.	8.1 gr.	8.5 gr.		
WIN ACT PIST	7.3 gr.	7.6 gr.	8.0 gr.	8.4 gr.			
Blue Dot	7.5 gr.	8.1 gr.	8.6 gr.	9.1 gr.	9.6 gr.	10.2 gr.	10.7 gr.
AA No. 5	7.8 gr.	8.1 gr.	8.5 gr.	8.9 gr.	9.2 gr.		
AA No. 7	9.3 gr.	9.8 gr.	10.4 gr.	10.9 gr.	11.4 gr.	12.0 gr.	
AA No. 9	11.5 gr.	12.0 gr.	12.6 gr.	13.2 gr.	13.8 gr.	14.4 gr.	14.9 gr.

■ indicates maximum load • use with caution

10MM AUTO - HORNADY BULLETS

200 GRAIN BULLETS

SECTIONAL DENSITY: 0.179
DIAMETER: 0.400"



#40060 HP-XTP
B.C.: 0.199 C.O.L.: 1.260"



#40077 FMJ-FP ENC
B.C.: 0.182 C.O.L.: 1.260"

POWDER	VELOCITY (FPS—feet per second)						
	850	900	950	1000	1050	1100	1150
Unique	5.3 gr.	5.7 gr.	6.0 gr.	6.4 gr.			
Hercs	5.3 gr.	5.8 gr.	6.2 gr.	6.6 gr.	7.0 gr.		
POWER PIST.	6.0 gr.	6.4 gr.	6.8 gr.	7.2 gr.	7.6 gr.		
VIRT 3N37	6.3 gr.	6.6 gr.	7.0 gr.	7.4 gr.	7.8 gr.		
IMR 4756	8.2 gr.	6.7 gr.	7.1 gr.	7.5 gr.	8.0 gr.		
WIN ACT PIST.	6.3 gr.	6.7 gr.	7.1 gr.	7.5 gr.			
800 X	6.0 gr.	6.6 gr.	7.1 gr.	7.6 gr.	8.1 gr.		
AA No. 5	6.8 gr.	7.2 gr.	7.6 gr.	8.0 gr.			
Blue Dot	6.9 gr.	7.3 gr.	7.8 gr.	8.2 gr.	8.6 gr.	9.0 gr.	9.4 gr.
HS-6	7.0 gr.	7.4 gr.	7.8 gr.	8.3 gr.			
HS-7	7.6 gr.	8.1 gr.	8.5 gr.	9.0 gr.	9.4 gr.		
AA No. 7	8.3 gr.	8.9 gr.	9.4 gr.	9.9 gr.			
AA No. 9	9.7 gr.	10.3 gr.	10.9 gr.	11.5 gr.	12.0 gr.	12.6 gr.	13.2 gr.

■ indicates maximum load • use with caution



The One You've Been Waiting For

Nosler's *Reloading Manual Number Four* is the most complete volume on reloading ever. A full 722 pages with never-before-published data on Nosler Ballistic Tip and Handgun bullets, and new data on Solid Base[®] and Partition[®] bullets.

- Feature articles by Bob Milek and Layne Simpson with a special foreword by Rick Jamison.
- Advice, anecdotes, personal experiences on over 70 cartridges by the industry's top writers including *Guns Magazine's* own Col. Charles Askins, Jon Sundra, Charles Petty and Ed Matunas, as well as Bill Jordan, Hal Swiggert, Jim Carmichel and many others.
- How-to sections on reloading rifle and handgun cartridges, reloading with progressive tools, evaluating handgun hunting loads and more.
- Deluxe gold-embossed leather-grain cover.

Available now at your favorite gun dealer.

NOSLER
Nosler[®] BULLETS

P.O. Box 671, Bend, Oregon 97709
(503) 382-3921



Save Enough to Pay for the Primers

Buy Nosler Handgun Bullets in 250 quantity Bulk Packs and save over 15% off the cost of buying the same bullets in our already low-priced 100-count boxes — enough extra savings for about 250 primers.

Add to the savings the kind of superb accuracy, consistency and expansion that you can really count on and you'll see why Nosler is your best choice for handgun hunting, target shooting or just plain plinking.

Nosler Handgun Bullet Bulk Packs are available in many popular calibers and weights and can be found at your

favorite gun shop or sporting goods store. And while you're there, pick up a copy of the new *Nosler Reloading Manual Number Three*. A full 528 pages, the manual contains never-before-published data on Nosler Handgun bullets as well as new data for Partition®, Solid Base and Ballistic Tip rifle bullets.

For a free catalog, write:
Nosler Bullets, Inc.
Dept. LB-1
P.O. Box 671
Bend, Oregon 97709

Nosler[®] BULLETS
Handgun

10MM AUTO - NOSLER BULLETS

The rain started before the first relay reached the "ram line." We had erected a couple of tent tops to protect a portion of the shooters. In rebuke, Mother Nature threw the rain sideways, soaking all competitors equally.

I stepped to the line and drew my Colt Delta Elite 10mm Auto.

This Delta has cycled handload and factory ammunition—including Norma's rough-mouth hollow point in its original inconsistent loading—with utter reliability since the first shot. It feeds empties from the magazine. *Good loads print five-shots inside seven inches at 100 meters.* How many autos do that out of the box?



It is not unusual for a Delta to print high at 50 or even 100 meters. Mine does, and I had to hold bottom of the foot on both chickens (50m), and pigs (100m). The above-zero point of impact at 100 meters reduced the chip of front sight I otherwise would have had to hold on turkeys (150m) and rams (200m). Despite foul weather and shooting the course standing, I toppled 22x40.

The 10mm flattens by half the lazy arc of a .45 ACP at 200 meters. The Ten is noticeably swifter, its retained energy greater. Rams, while not flung from the rail, tip decisively.

The Nosler® 180 JHP seated over a carefully worked-up charge of Accurate No. 7 powder in Winchester brass with Winchester Large Pistol primer performs the work. Velocity of my load, measured on Ken Oehler's Model 33 and 3SP chronographs, averages 1,150 fps—a cool 200 fps increase over the same projectile fired from a .40 S&W for a meat-grinding gain in punch.

The 150 JHP may be safely pushed to 1,350 fps in the 1:16-inch twist, five-inch barrel. This is an astonishingly flat-shooting combination. It expands in flesh beyond the distance at which a shot is made with dignity. Nevertheless, if through keenly developed skill and experience you are inclined to stalk deer with the 10mm, select a jacketed hollow point of greater sectional density, particularly the 180 JHP.

DAVID BRADSHAW

David is former Chairman of the Safety Committee and record-setting Champion of the International Handgun Metallic Silhouette Association. He incorporates marksmanship in art and sculpture with steel and dynamite.

10MM AUTO - NOSLER BULLETS

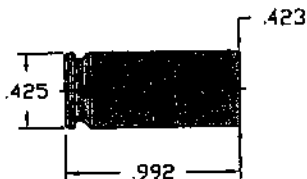

RIFLE:	Barrel:	Springfield Omega
	Length:	6"
	Twist:	1-16"
CASE:		Winchester
PRIMER:		Win. WLP

Comments from the lab

The 10mm Auto is one of the more powerful pistol cartridges on the market today. For this reason, it is one of the few pistol cartridges that is capable of efficiently taking deer-sized game animals, with proper shot placement of course. If you choose to use the 10mm for hunting applications, we would recommend using either our 170- or 180-grain bullets.

Like most pistol cartridges, the 10mm Auto headspaces off of the case mouth. When loading for this cartridge, bell the case mouth just enough to reliably guide the bullet into position, and secure the bullet with a taper crimp. Using this seating and crimping procedure will help ensure proper headspacing.

The S.A.A.M.I. overall cartridge lengths for this cartridge range from 1.240" minimum to 1.260" maximum. Seating to anywhere in this range is acceptable, but there may be a depth at which your particular firearm performs the best.

10MM AUTO - NOSLER BULLETS

Nosler

135 Grain



135 gr.
Hollow Point

*Most Accurate Load Tested

**Compressed Load

Ballistic Coefficient .093
Sectional Density .121

Powder	Charge Weight In Grains	Muzzle Velocity (fps)	Load Density
W 231	Max. 7.5	1289 fps	43%
	7.0	1224 fps	40%
	6.5*	1160 fps	38%
UNIQUE	Max. 8.5	1340 fps	49%
	8.0	1263 fps	46%
	7.5*	1185 fps	43%
AA-No. 5	Max. 11.0	1417 fps	64%
	10.5	1362 fps	61%
	10.0*	1307 fps	58%
HS 6	Max. 11.0	1356 fps	64%
	10.5	1280 fps	61%
	10.0*	1205 fps	58%
BLUE DOT (Most Accurate Powder Tested)	Max. 12.5	1459 fps	72%
	12.0	1383 fps	69%
	11.5*	1308 fps	66%
AA-No. 7	Max. 13.2	1405 fps	76%
	12.7	1341 fps	73%
	12.2*	1278 fps	71%

Use Maximum Loads with Caution

10MM AUTO - NOSLER BULLETS

Nosler[®]

150 Grain



150 gr.
Hollow Point

*Most Accurate Load Tested

**Compressed Load

Ballistic Coefficient .106

Sectional Density .134

Powder	Charge	Weight in Grains	Muzzle Velocity (fps)	Load Density
W 231	Max.	7.0	1197 fps	46%
		6.5	1132 fps	43%
		6.0*	1068 fps	40%
UNIQUE (Most Accurate Powder Tested)	Max.	8.0	1239 fps	53%
		7.5	1198 fps	50%
		7.0*	1157 fps	46%
AA-No. 5	Max.	10.1	1296 fps	67%
		9.6	1240 fps	64%
		9.1*	1184 fps	60%
HS 6	Max.	10.5	1290 fps	70%
		10.0	1223 fps	66%
		9.5*	1156 fps	63%
BLUE DOT	Max.	11.2	1292 fps	74%
		10.7	1220 fps	71%
		10.2*	1148 fps	68%
AA-No. 7	Max.	12.7	1358 fps	84%
		12.2	1306 fps	81%
		11.7*	1253 fps	77%

Use Maximum Loads with Caution

10MM AUTO - NOSLER BULLETS

Nosler

170 Grain



170 gr.
Hollow Point

*Most Accurate Load Tested

**Compressed Load

Ballistic Coefficient .137

Sectional Density .152

Powder	Charge Weight in Grains	Muzzle Velocity (fps)	Load Density
AA-No. 2	Max. 6.3	1073 fps	50%
	5.8	998 fps	46%
	5.3*	923 fps	42%
UNIQUE (Most Accurate Powder Tested)	Max. 7.0	1112 fps	55%
	6.5*	1025 fps	51%
	6.0	958 fps	47%
AA-No. 5	Max. 9.2	1226 fps	73%
	8.7	1146 fps	68%
	8.2*	1066 fps	64%
BLUE DOT	Max. 10.5	1226 fps	83%
	10.0	1166 fps	79%
	9.5*	1106 fps	75%
AA-No. 7	Max. 11.5	1240 fps	91%
	11.0	1168 fps	87%
	10.5*	1111 fps	83%
2400	Max. 12.4*	1130 fps	98%
	11.9	1070 fps	94%
	11.4	1010 fps	90%

Use Maximum Loads with Caution

10MM AUTO - NOSLER BULLETS

Nosler

180 Grain



180 gr.
Hollow Point

*Most Accurate Load Tested
**Compressed Load

Ballistic Coefficient .147
Sectional Density .181

Powder	Charge Weight in Grains	Muzzle Velocity (fps)	Load Density
W 231 (Most Accurate Powder Tested)	Max. 5.8	1019 fps	41%
	5.3	961 fps	37%
	4.8*	904 fps	34%
UNIQUE	Max. 6.8	1092 fps	48%
	6.3	1051 fps	45%
	5.8*	993 fps	41%
AA-No. 5	Max. 8.7	1142 fps	62%
	8.2	1079 fps	58%
	7.7*	1017 fps	55%
HS 6	Max. 8.6*	1122 fps	61%
	8.1	1057 fps	57%
	7.6	992 fps	54%
BLUE DOT	Max. 10.2	1190 fps	72%
	9.7	1130 fps	69%
	9.2*	1070 fps	65%
AA-No. 7	Max. 11.0	1190 fps	78%
	10.5	1143 fps	74%
	10.0*	1096 fps	71%

Use Maximum Loads with Caution



When You Need ALL the Facts...

The Sierra 4th Edition Reloading Manuals have the information you need. Rifle and Handgun reloading information are in two separate volumes, and each one covers its subject thoroughly. No matter what brand of bullet, powder, or primer you like to use, the Sierra manuals give you the full story.

They also help you with practical tips on hunting and target shooting reloading specialties from the people who are recognized as top-flight experts—like Bob Milek on loads for handgun hunters or David Tubb for big bore target rifle.

Available at your reloading retailer or call direct 1-800-223-8799. When you reload with Sierra, you reload with the Bulletsmiths®!

SIERRA

The Bulletsmiths®

Here's everything you
need to know about
your toughest reloading
problems...

1-800-223-8799

That's the Sierra Bullets TOLL-FREE Tech Line. Our Bulletsmiths[®] are on hand from 7 am to 4 pm Central Time, Monday through Friday, ready to answer your reloading questions. No matter what brand of powder or bullet, no matter the caliber or conditions, the Bulletsmiths[®] can help you develop the load to suit your need.

So don't be bashful, go ahead and give us a call.

SIERRA
The Bulletsmiths[®]

10MM AUTO - SIERRA BULLETS

10mm Auto

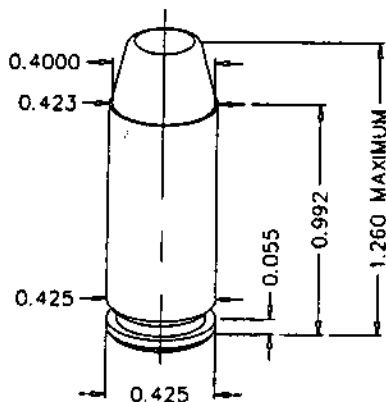

Test Specifications/ Components

Firearm Used: Colt Delta Elite

Barrel Length: 5"

Twist: 1 x 16"

Case: Norma

Trim-to Length: 0.987"

Primer: CCI-300

Remarks:

The 10mm Auto was first introduced in 1983 in the ill-fated Bren Ten pistol marketed by Dornaus & Dixon. Based largely on the Czech CZ-75 9mm auto, the Bren Ten incorporated many ideas of noted combat pistol authority, Col. Jeff Cooper. Ammunition was first commercially

loaded by Norma, and the 10mm appeared to have a bright future ahead of it. Unfortunately, delivery problems plagued Dornaus & Dixon from the beginning, eventually forcing them into bankruptcy. With the Bren Ten out of production, the fate of the 10mm Auto remained in limbo until 1987, when Colt chambered it in their Delta Elite pistol. Smith & Wesson followed suit shortly after, offering several large autos chambered for the 10mm.

Sierra currently produces jacketed hollow point designs in 135, 150, 165 and 180 grain weights that are well suited to self-defense, competition and hunting with the 10mm Auto. For situations requiring deeper penetration with little or no expansion, the 190 grain full profile jacket is an excellent choice. Like any rimless autoloading cartridge headspacing on the case mouth, the 10mm requires a slight taper crimp for reliable functioning. In our testing, we found Accurate Arms #7 and Blue Dot to be outstanding performers, delivering both high velocity and excellent accuracy. The 10mm is an inherently accurate cartridge, routinely giving ten shot groups of under one inch here in the Sierra test range. With the energy levels available in full power loads, the 10mm is quite capable of cleanly taking deer and boar sized game with proper shot placement.

This makes it all the more ironic, as its power may well have proved to be the cause of its downfall. With an OAL of 1.260 inches, it requires a large (45 caliber) frame pistol to accommodate the round. Along with its impressive performance, came equally impressive (and to some, intimidating) recoil. Several of the law enforcement agencies which first adopted the 10mm as a service round requested a milder loading, pushing a 180 grain bullet at a nominal 950 fps for milder recoil and faster recovery time. Seeing an opportunity, Smith & Wesson wasted no time in developing a shortened round which met these ballistic parameters, and could be housed in a smaller (9mm) sized frame. The resulting cartridge, known as the 40 S&W, has taken much of the law enforcement market share, relegating the 10mm primarily to sporting and hunting applications.

10MM AUTO - SIERRA BULLETS

10mm Auto *continued*

#8425 .400" 135 gr. JHP
C.O.A.L. 1.250"



Powder/Velocity -	1100	1150	1200	1250	1300
AA- No. 5	8.9	9.2	9.5	9.7	10.0
Univ. Clays	7.8	7.9	8.1	8.2	8.3
Viht N340	7.1	7.4	7.7	8.0	8.3
Viht 3N37	8.7	8.9	9.2	9.4	9.7
AA-No. 7	10.9	11.5	12.2	12.9	
HS-7	10.1	10.5	10.9	11.3	11.8
Blue Dot	10.9	11.3	11.8	12.2	
Energy/ft.lbs.	363	397	436	469	507

	Powder	Grains	Velocity	Ft. lbs.
Accuracy Load	Viht N340	8.0	1250	469
Hunting Load	Viht N340	8.3	1300	507

#8430 .400" 150 gr. JHP
C.O.A.L. 1.250"



Powder/Velocity -	1000	1050	1100	1150	1200	1250
Bullseye	5.7	6.0	6.3			
231	6.4	6.7	7.1			
AA-No. 2	5.9	6.3	6.6			
Univ. Clays	6.3	6.6	6.9	7.2	7.5	7.8
Unique	7.3	7.6	7.9	8.2		
SR4756	8.0	8.4	8.8	9.2	9.6	9.9
AA-No. 5	9.0	9.3	9.6	10.0		
Viht N340			7.0	7.4	7.8	8.2
HS-6	8.7	9.1	9.5	9.9	10.4	10.8
Viht 3N37			8.1	8.5	8.8	9.2
Blue Dot	9.9	10.3	10.7	11.1	11.5	12.0
HS-7	10.8	11.3	11.8	12.4	12.9	13.1
AA-No. 7	10.6	11.1	11.6	12.1	12.6	13.0
Energy/ft.lbs.	333	367	403	440	480	520

	Powder	Grains	Velocity	Ft. lbs.
Accuracy Load	AA-No. 7	12.6	1200	480
Hunting Load	Blue Dot	12.0	1250	520

INDICATES MAXIMUM LOAD - USE CAUTION
LOADS LESS THAN MINIMUM CHARGES SHOWN ARE NOT RECOMMENDED.

10MM AUTO - SIERRA BULLETS

10mm Auto *continued*

#8445 .400" 165 gr. JHP
C.O.A.L. 1.250"



Powder/Velocity -	950	1000	1050	1100	1150	1200
Bullseye	5.4	5.7	5.9			
231	5.9	6.2	6.4			
AA-No. 2	5.6	5.9	6.1	6.4		
Univ. Clays	6.3	6.6	6.9	7.2		
Unique	6.1	6.4	6.7	7.1		
SR4756	7.2	7.6	8.0	8.3	8.6	
AA-No. 5	7.7	8.1	8.4	8.7	9.1	9.5
Vihl N340	6.0	6.5	7.0	7.6		
HS-6	8.1	8.4	8.7	9.0	9.3	
Vihl 3N37	7.3	7.6	7.9	8.2	8.5	
Blue Dot	9.3	9.6	9.9	10.3	10.7	11.0
HS-7	9.5	9.9	10.3	10.7	11.0	
AA-No. 7	9.6	10.1	10.6	11.1	11.5	11.9
Energy/ft.lbs.	331	367	404	443	485	528

	Powder	Grains	Velocity	Ft. lbs.
Accuracy Load	HS-6	9.0	1100	443
Hunting Load	Blue Dot	11.0	1200	528

INDICATES MAXIMUM LOAD - USE CAUTION
LOADS LESS THAN MINIMUM CHARGES SHOWN ARE NOT RECOMMENDED.

10MM AUTO - SIERRA BULLETS

10mm Auto *continued*

#8460 .400" 180 gr JHP
C.O.A.L. 1.250"



Powder/Velocity--	850	900	950	1000	1050	1100
Bullseye	4.7	5.0	5.2			
231	5.0	5.3	5.6			
AA-No. 2	4.8	5.2	5.6	5.9		
Univ. Clays	5.2	5.5	5.7	6.0	6.3	
Unique	5.6	5.9	6.3			
SR4756	6.2	6.5	6.8	7.1	7.4	
AA-No. 5	7.1	7.5	7.9	8.4		
Vht N340	5.3	5.6	5.9	6.2	6.6	
HS-6	7.0	7.4	7.8	8.2	8.6	
Vht 3N37	6.3	6.6	6.9	7.2	7.5	
Blue Dot	8.2	8.8	9.0	9.4	9.8	10.1
MS-7		9.1	9.6	10.1	10.6	
AA-No. 7	8.5	9.0	9.5	10.0	10.5	11.1
Energy/ft. lbs.	289	324	361	400	441	484

	Powder	Grains	Velocity	Ft. lbs.
Accuracy Load	AA-No. 7	11.1	1100	484
Hunting Load	Blue Dot	10.1	1100	484

INDICATES MAXIMUM LOAD - USE CAUTION
LOADS LESS THAN MINIMUM CHARGES SHOWN ARE NOT RECOMMENDED.

10MM AUTO - SIERRA BULLETS

10mm Auto *continued*

#8480 .400" 190 gr FPJ Match
C.O.A.L. 1.250"



Powder/Velocity--	800	850	900	950	1000	1050
Bullseye	4.5	4.8	5.1			
231	4.6	4.9	5.2			
AA-No. 2	4.6	4.9	5.2	5.4		
Univ. Clays	5.1	5.3	5.5	5.7	5.9	6.1
Unique	5.1	5.6	6.0			
SR4758	5.5	6.0	6.5	7.0	7.3	
AA-No. 5	6.5	7.0	7.5	8.0		
Vih1 N340	5.0	5.3	5.6	5.9	6.2	6.5
HS-6	7.0	7.3	7.6	7.9		
Vih1 3N37	5.8	6.1	6.4	6.7	7.0	7.3
Blue Dot	8.3	8.6	8.9	9.2	9.5	9.9
HS-7	8.3	8.8	9.3	9.8	10.2	
AA-No. 7		8.6	9.0	9.4	9.8	10.3
Vih1 N350	5.8	6.1	6.4	6.7	7.0	
Energy/ft.lbs.	270	305	342	381	422	465

	Powder	Grains	Velocity	Ft. lbs.
Accuracy Load	AA-No. 7	9.8	1000	422
Hunting Load	Blue Dot	9.9	1050	465

INDICATES MAXIMUM LOAD - USE CAUTION

LOADS LESS THAN MINIMUM CHARGES SHOWN ARE NOT RECOMMENDED.

SPEER®

SPEER®

SPEER®

SPEER®

SPEER® HAS A MORE POTENT RECIPE FOR PUNCH.

JACKET OPENING ENGINEERED FOR RELIABLE EXPANSION, EVEN AT LOW VELOCITIES.

DOUBLE-SWAGED FOR TIGHT DIAMETER CONTROL AND IMPROVED ACCURACY.

"SOLDER-TYPE" BOND OF LEAD CORE TO JACKET.

MOLTEN 1.5% ANTIMONY LEAD IS POURED INTO JACKET, UNIFYING CORE AND JACKET.

HEAVY JACKET IS 45.6% THICKER THAN OLD DESIGN, GIVING BULLET GREATER STRENGTH AND WEIGHT RETENTION DURING IMPACT AT HIGH VELOCITIES.

THE IMPROVED 165 GRAIN—.308" HOT-COR™ BULLET.



308, 165 GR.
72% RETAINED
WEIGHT. SHOT INTO
BALLISTIC TEST MEDIA.

The secret of its success—Hot-Cor.™ Our own special process that injects molten lead into the jacket, rather than forcing in a cold lead slug. The result: greater expansion and weight retention than conventional "cold core" bullets. With deadly accuracy and consistency. Shot after shot after shot.



SPEER

YOUR SHOOTING PARTNER.
CCI • SPEER • NCBS • OUTERS • WEAVER

10MM AUTO - SPEER BULLETS

The idea of a 40 caliber, semi-auto pistol cartridge has been around for many years and some wildcat versions have briefly held the interest of pistol shooters. But it wasn't until 1983 that a commercial version appeared.

In that year, the firm of Dornaus & Dixon announced the introduction of the 10mm Auto cartridge in a heavy combat pistol, the Bren Ten. The new cartridge was not directly based on any existing cartridge and was developed for D&D by Norma of Sweden. The cartridge was capable of pushing a .400" 200 grain bullet at close to 1200 feet/sec making it just a little less powerful than hunting loads in the potent 41 Magnum revolver.

Manufacturing problems resulted in few Bren Tens (and fewer magazines) actually reaching consumers. It wasn't until 1987 that Colt announced production guns in this caliber. The Delta Elite is a basic M1911 design beefed up to handle the high-pressure 10mm cartridge. Within 18 months, most other U.S. pistol makers offered a 10mm and several ammo companies were producing both hollow point and FMJ loads.

The 10mm received a lot of press attention when the FBI began looking for a new service pistol to replace existing 9mm and 38 Special handguns. They experimented with reduced loads driving a 180 grain bullet at 980 feet/sec and ultimately found a cartridge which combined tolerable recoil with excellent terminal ballistics. There isn't an official name for this reduced 10mm load, but it is commonly referred to as "Subsonic," the "FBI load," or occasionally, the "10 Lite". However, the reduced-pressure, 10mm subsonic load is no weakling—it is an excellent law enforcement cartridge for departments that

choose large-frame semi-autos.

The full-power 10mm Auto is among just a few semi-auto pistol cartridges which can be used on deer. Check with local hunting regulations, however. Generally, 180 grain Gold Dot HP bullets offer sufficient penetration to handle smaller whitetail at close range. The 155 grain GDHP allows very high velocity but shouldn't be used on deer because its penetration at such speeds is less than the heavier bullets.

Hikers who frequent bear country often choose the 10mm as a trail gun. It is more compact than a heavy-frame revolver, holds more cartridges and its performance exceeds that of the 357 Magnum. For this application, we feel that Speer's tough, 200 grain TMJ is an excellent choice for deep penetration.

Handloaders find that medium burning rate pistol propellants give the best results. The exception is the 200 grain bullet, where AA #9 and 2400 gave good velocities. The 10mm uses large pistol primers. The overwhelming success of the 40 S&W by sports shooters and law enforcement has eroded the 10mm's market position significantly in the last five years. At press time, Springfield and Glock were the only firms still producing 10mm pistols. The selection of factory ammo has also diminished compared to the 40 S&W. As long as cases are available, this should have little effect on the handloader.

These loads do not exceed the 37,500 psi pressure limit established by the industry.

10MM AUTO - SPEER BULLETS

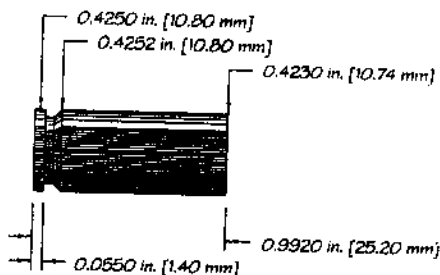

Max. Case Length: 0.992" **Test Firearm:** Smith & Wesson Model 1006
Trim-to Length: 0.982" **Case:** Hornady
Max. Cart. Length: 1.260" **Primers:** CCI 300, 350
RCBS Shellholder: #27
Barrel Length: 5"
Twist: 1-16"



.400" Dia.
155 Grain

Sect. Density .138

	40/10mm RND	40/10mm GD-HP				
Ballistic Coefficient	0.125	0.123				
C.O.L. Tested At	1.250"	1.250"				
Speer Part No.	4399	4400				

Powder	Wt. Grs.	Mzt. Vel.	Powder	Wt. Grs.	Mzt. Vel.	Powder	Wt. Grs.	Mzt. Vel.
AA	13.0	1320	Unique	8.5	1246	Vlht.	8.0	1180
#7	12.0	1187		7.5	1091	N340	7.2	1034
Vlht.	9.8	1312	WAP	9.5	1245	AA	10.2	1176
3N37	8.9	1140		8.5	1073	#5	9.2	1004
	12.0	1291	HS-6*	10.5	1223		8.4	1162
Blue Dot	11.0	1164		9.5	1095	WSF	7.6	1017
	12.0	1254	231	7.7	1183			
HS-7*	11.0	1094		7.0	1062			

Notes: Bold print denotes maximum loads. They should be used with caution.
 * CCI Magnum Primer used with this powder.

10MM AUTO - SPEER BULLETS



**.400" Dia.
180 Grain**

Sect. Density .161

	40/10mm TMJ	40/10mm GD-HP				
Ballistic Coefficient	0.143	0.143				
C.O.L. Tested At	1.250"	1.250"				
Speer Part No.	4402	4406				

Powder	Wt. Grs.	Mzi. Vel.	Powder	Wt. Grs.	Mzi. Vel.	Powder	Wt. Grs.	Mzi. Vel.
	11.0	1295		10.0	1150		7.5	1120
Blue Dot	10.0	1105	Vht.	9.0	1027	WSF	6.8	1001
	12.8	1214	3N37	8.0	1138		9.4	1118
2400*	11.5	1051	Unique	7.2	1043	540*	8.5	1010
	12.0	1180		9.6	1129		9.2	1117
AA #7	11.0	1065	AA #5	8.6	1032	HS-6*	8.3	1019
	10.6	1150		8.5	1124			
HS-7*	9.7	1037	WAP	7.7	1012			



**.400" Dia.
200 Grain**

Sect. Density .179

	40/10mm TMJ					
Ballistic Coefficient	0.208					
C.O.L. Tested At	1.250"					
Speer Part No.	4403					

Powder	Wt. Grs.	Mzi. Vel.	Powder	Wt. Grs.	Mzi. Vel.	Powder	Wt. Grs.	Mzi. Vel.
AA #9*	14.0	1216	AA #7	11.6	1151	Unique	7.5	1092
	12.5	1083		10.5	1058		6.8	987
Blue Dot	10.0	1159	Vht.	8.3	1094	HS-7*	10.2	1084
	9.0	1043	3N37	7.5	1006		9.2	1008
	12.0	1152		9.1	1094		9.0	1077
2400	11.0	1059	HS-6*	8.2	1006	540*	8.1	1004

Notes: Bold print denotes maximum loads. They should be used with caution.
* CCI Magnum Primer used with this powder.

THE ALL-IN-ONE RELOADING KIT

For the Serious Handloader

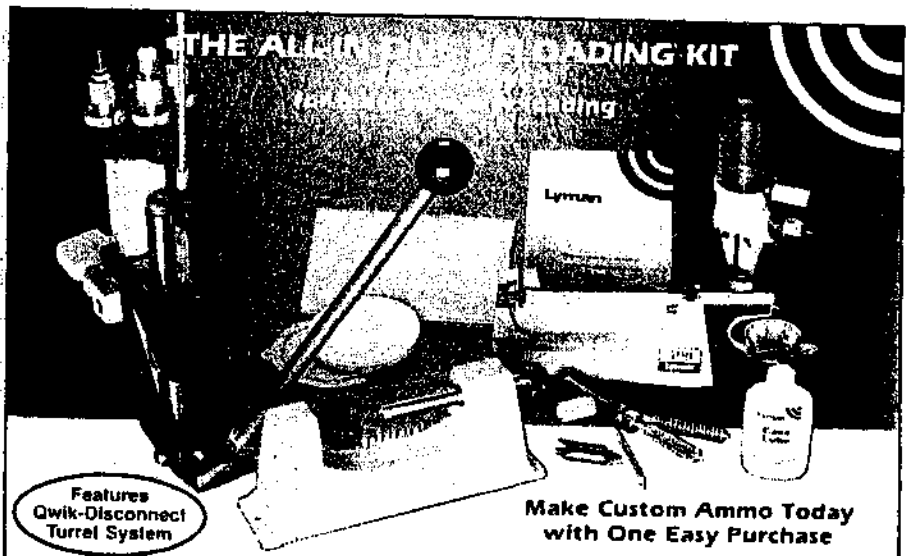

Features
Qwik-Disconnect
Turret System

Make Custom Ammo Today
with One Easy Purchase

Our popular Expert Kit is now even better since we upgraded to the versatile T-MAG Press. Combines the speed of a turret press with the strength and ease of compound leverage. Accepts all std. 7/8" x 14 dies. Removable turret holds up to 6 dies for easy set-up and storage.

This Kit combines everything needed to load quality pistol or rifle ammunition except the components. Available with or without a die set.

Lyman's Expert Kit includes:

- T-Mag Press complete
- Universal[®] case trimmer and Pilot Pack
- Model 500 Powder Scale
- Model 55 Powder Measure
- Misc. accessories and case prep gear
- "How To" Reloading Guide

Interested in Handloading? Save money and time! Ask for the Lyman Expert Kit. Available at your dealer today!

Write for free mini-catalog.

Questions?
Call toll free 1-800-22-LYMAN.

Lyman Dept 000, Route 147
Middlefield, CT 06455

NEW PRODUCTS REPORT

CAST YOUR OWN

And cast high cost to the wind

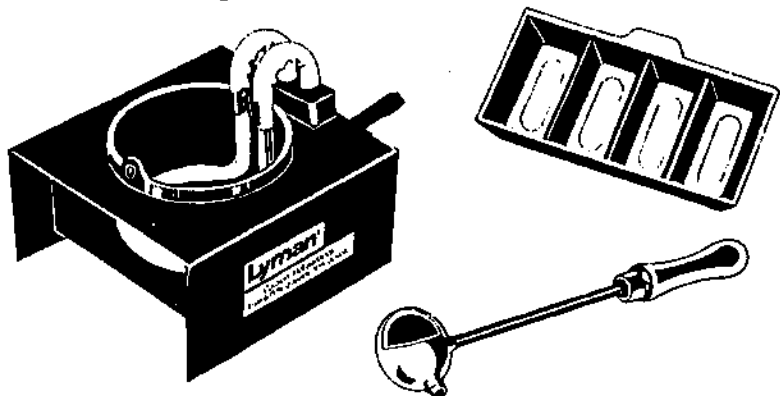

Enjoy the satisfaction of casting your own bullets, fishing jigs or sinkers. The fully electric Mini-Mag Furnace features a long life, heavy duty heating coil that will give you years of quality melting.

The Mini-Mag Furnace is designed for use with a ladle and has an operating capacity of 8 lbs. It reaches a temperature of over 700° in about 20 minutes and the stable metal base can be used as a pre-heater for mould blocks. The furnace comes with a 3 prong safety cord.

It is the best capacity value available today. Try Lyman and cast with confidence.

See your Lyman dealer for our complete line of casting equipment. Also available direct for \$39.95 postpaid. Send check or money order. Visa/MC accepted. Write for free mini-catalog.

Questions? Call toll free 1-800-22-LYMAN

Lyman*

Dept 000, Route 147 Middlefield, CT 06455

10MM AUTO - LYMAN BULLETS

Reloading Data Introduction:

The data listed in this section have been tested by our technicians and found to be safe when loaded with our test components and fired (under our laboratory controlled conditions) in our testing equipment. Since Lyman Products Corporation has no control over the manufacture of the various components listed, the actual loading, choice or condition of the firearms and components used, no responsibility for use of this data is implied or assumed.

Components:

The reader should bear in mind that the components listed are not of Lyman manufacture. Therefore, it is impossible that production changes affecting ballistic performance can occur at any time without our knowledge. If there is ever a question as to the correctness of the component specified, write to its manufacturer.

Starting Load:

It is essential that the reader begin with the suggested weight of powder listed in this bracket and work up slowly (following load development precautions) to his best performing load. The novice should use only the "starting load" for a period of time until he builds confidence and experience. Never decrease this charge as an increase in pressure could be encountered.

Maximum Load:

All loads which are listed as maximum were tested and classified as maximum by our technicians in accordance with our laboratory standards. Under no circumstances should these loads be exceeded, nor should they be quickly accepted by the reader as a safe working maximum for his particular rifle or pistol.

Many reloaders misinterpret the meaning of the "maximum load." They wrongly assume that if a high pressure load proved safe in a test laboratory then it is equally safe under any and all conditions. This is not true. The reader must start with the "starting load" and work up his load carefully. Working with his particular firearm and component combination, he may encounter signs of excess pressure before he reaches the maximum charge listed.

The technician classifies a load as maximum after carefully considering many aspects of its ballistic performance. The maximum average pressure of the load is not the only criteria. Often a load having an acceptable maximum average pressure will be rejected (or reduced) due to its erratic performance. Accuracy must also be considered, particularly when dealing with cast lead alloy bullets. In all instances, the maximum listing represents what our technicians consider to be the maximum working combination for the bullet, powder and caliber listed. These loads do not exceed SAAMI standards.

Accuracy Loads:

When a load is noted as such in the data tables proper, it means that the given combination of components produced the most uniform internal ballistics of any load tested utilizing that particular bullet design.

10MM AUTO - LYMAN BULLETS

Unless noted in "Comments," the accuracy load was not fired at targets. The load, however, does have a high potential—assuming all external factors are optimum—for producing outstanding accuracy since uniform internal ballistics are critical to accuracy on target. You cannot have one without the other.

Test Parameters:

Velocities shown were taken at fifteen feet and not corrected to the muzzle.

Each test string began with a clean dry barrel and consisted of ten shots.

Loads exhibiting erratic internal ballistics were not pursued.

We had no problem with leading in any of our testing.

Bullets:

Bullet numbers are listed in the introductory specifications for each cartridge and in the headline above the appropriate data block—along with an illustration of that particular bullet.

Please note these bullets are artists' rendering. Comparing your bullet against the drawing could reveal minor differences. Furthermore, minor changes are sometimes made to bullets. These drawings, which appear throughout the data sections, are for general reference only and are not intended to be a precise representation.

Bullet alloy is noted as is the exact weight of each tested bullet.

Not all cast bullets within a given caliber are intended to perform equally. We have used them in the most appropriate chamberings.

Powders:

We have limited our testing to those powders which are manufactured in the United States and which are readily available to the consumer. The following brands are listed: Dupont (now IMR), Winchester, Hercules, Alcan, Hodgdon and Gearhart-Owen.

Compressed Loads:

All compressed loads are indicated with a +. Depending upon the volume of the specific cartridge case used by the reader, he may, or may not, have difficulty starting bullets in such loads. If the bullet will not start, reduce the load sufficiently so that 1/10" of space remains in the case neck: Start the bullet into the case and use whatever additional pressure is required to fully seat the bullet. Failure to comply could result in a bulged case.

Filler Wads:

Dacron filler wads in the form of 1/4-inch thick batting were used in conjunction with cast bullet loads, where indicated. This material can be purchased in most yard-goods stores. It should be cut into squares, which seal the case.

When developing a load, if a wad is desired, its should be used from the beginning as the charge weight is increased. It should never be added as an afterthought, once a maximum load has been established, since its presence could result in a pressure increase of 2,000 CUP or more.

10MM AUTO - LYMAN BULLETS

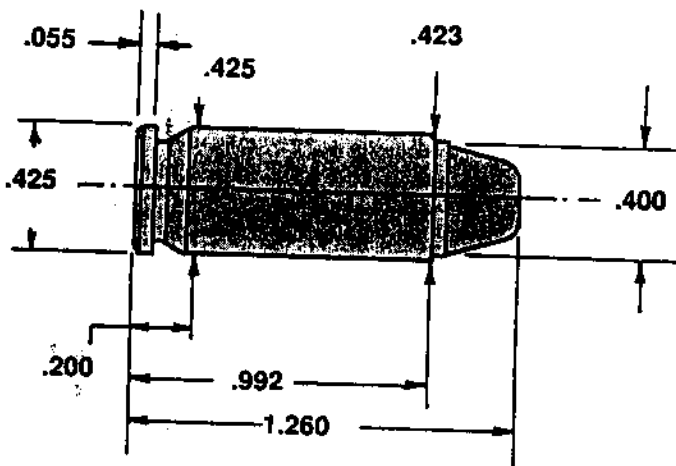

COMMENTS:

This is a high performance semi-auto pistol cartridge with applications in law enforcement and hunting.

The 10mm Auto cartridge headspaces on the mouth and therefore case trimming must be uniform and accurate. Do not reduce cases below the recommended trim-to length. Additionally do not roll crimp bullets as this will prevent the case from properly headspacing on its mouth. A modest taper crimp is also suggested.

It is important not to seat bullets to a shorter length than listed in any handgun cartridge; but especially so in this one. Pressures can be raised dramatically with deep seating.

Winchester 231 frequently provided the best accuracy though not the highest velocities when used in this cartridge. Cast bullet #401633 is an excellent choice for hunting.

TEST COMPONENTS:

Cases	Norma
Trim-to Length989"
Primers	CCI 300
Primer Size	Large Pistol
Lyman Shell Holder	No. 15
Cast Bullets Used	(Sized to .401" dia.)
	#401043, 175 gr.
	#401638, 175 gr.
	#401633, 200 gr.

TEST SPECIFICATIONS: (Velocity & Pressure)

Firearm Used	Universal Receiver
Barrel Length	5"
Twist	1-16"
Groove Dia.400"

10MM AUTO - LYMAN BULLETS



#401043

175 gr., (#2 Alloy) 1.260" OAL

POWDER	Sugg. Starting Grains	Velocity fps	Pressure C.U.P.	Max. Load Grains	Velocity fps	Pressure C.U.P.
Bullseye	5.5	1069	22,200	6.5	1199	28,300
Red Dot	5.5	1087	24,500	6.2	1194	29,300
Unique	6.1	1097	23,300	7.0	1224	28,800
Blue Dot	9.0	1100	21,100	10.4	1245	28,100
700X	5.2	1102	24,700	5.8	1170	28,200
800X	7.0	1090	20,300	8.2	1242	27,600
231	5.5	1023	20,300	6.7	1189	28,800
HS-6	8.0	1071	20,300	9.4	1236	29,000
AA 5	7.0	1038	18,100	8.2	1236	28,400



#401638

175 gr., (#2 Alloy) 1.253" OAL

POWDER	Sugg. Starting Grains	Velocity fps	Pressure C.U.P.	Max. Load Grains	Velocity fps	Pressure C.U.P.
Bullseye	5.9	1115	23,500	6.4	1197	28,400
Red Dot	5.4	1113	23,900	6.0	1152	28,700
Unique	6.1	1104	22,900	6.8	1180	28,900
Blue Dot	9.3	1175	23,800	10.4	1275	29,900
800X	7.7	1092	23,300	8.6	1269	28,300
231	5.9	1115	24,000	6.5	1181	29,400
WSL	5.4	1096	24,300	6.0	1154	28,500
WSF	6.2	1094	22,800	7.0	1176	28,600
AA 5	7.2	1138	24,000	7.6	1196	28,700

Note: Loads shown in shaded panels are maximum.

10MM AUTO - LYMAN BULLETS



#401633

200 gr., (#2 Alloy) 1.253" OAL

POWDER	Sugg. Starting Grains	Velocity fps	Pressure C.U.P.	Max. Load Grains	Velocity fps	Pressure C.U.P.
Bullseye	5.0	1034	24,300	5.6	1102	29,300
Red Dot	5.1	1034	24,800	5.9	1150	29,800
Unique	5.7	1031	24,200	6.4	1154	29,600
Blue Dot	8.1	1093	24,500	9.0	1173	29,400
800X	6.8	1101	23,300	7.7	1181	28,400
231	5.3	1045	23,300	6.0	1108	28,200
WSL	4.7	1025	23,000	5.5	1104	29,500
WSF	5.8	1036	22,600	6.4	1117	28,600
AA 7	9.1	1084	22,800	10.2	1184	28,800

Note: Loads shown in shaded panels are maximum.

10MM AUTO - ACCURATE POWDERS

Introduction

There has been a re-evaluation of the criteria for selecting data for inclusion. This means there will be some disagreement with previous data. The data in this guide takes precedence over all prior publications. *Previous editions of this loading guide should be discarded.*

For instance, we left out load combinations that were 'position sensitive'. This is what occurs when the load density is low. Velocity with the powder at the bullet is different from the velocity with the powder at the primer. More of these were noted with the ball propellants than with the extruded propellants.

In light of the growth of IPSC shooting, 38 Super Auto loads that make the 'major' classification (bullet weight x velocity = 175,000) are identified. While we have tested many combinations of components in 9mm Luger to attempt to meet 'major' requirements, we have not been able to find a load that makes the power floor for 'major' without exceeding SAAMI pressure recommendations. And while we were able to find loads for 38 Super Auto, they were not with lighter bullets. Turn to the data section for specific details.

In the charge tables, the 'START' charge listed for each load is our suggested beginning point with the components listed. There is the possibility that changing the named components could cause the maximum charge to be excessive, thus a reduction of the charge would be necessary. Some batches of military brass may require reducing the maximum charge by 8-12% to keep chamber pressure in line.

If you find signs of excessive pressure while using loads in this loading guide, STOP TESTING and verify all data and loading procedures. If they seem to be in order, check with our lab facility before proceeding.

Charge weights were obtained using industry standard pressure barrels. When time permitted, off-the-shelf weapons were used to obtain velocity figures. The guns used are noted.

In reloading, the prime concern should always be SAFETY. Always wear eye protection when reloading, even when working with the 'non-volatile' components. Always keep the reloading area clean. Never have more than one propellant within easy reach at any given time. Avoid having similar looking bullets of different weights on the bench at the same time. Read the safety notes before loading.

We have not found magnum primers to offer any particular advantage with our handgun powders. But, there are some rifle cartridges where they were used.

Handgun loads using the slower powders (No.7, No.9, and 1680) require heavy crimp and high bullet pull to insure consistency - particularly with cast bullet loads or in extremely cold weather. Be sure your dies are capable of this, otherwise the consistency of the load will be affected.

In the text, bullet weights for cast bullets - identified by (L) are actual weights, not the nominal weights.

10MM AUTO - ACCURATE POWDERS

10mm AUTO

The 10mm Auto was introduced in 1983 along with the Bren Ten semi-automatic pistol by Dornaus and Dixon.

The ammunition was originally loaded by Norma using a 200 grain full metal jacketed bullet with a truncated cone shape. The Bren Ten pistol is now part of history; however, the 10mm Auto cartridge was too good to die and is now chambered by several manufacturers including Colt and Smith & Wesson.

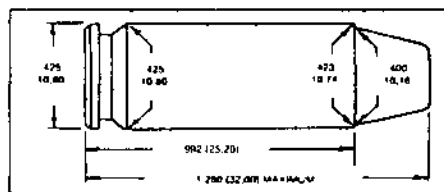

The 10mm Auto provides a handgunner with the power of a .357 Magnum revolver with the increased magazine capacity and rapid reload capability of an automatic pistol.

The SAAMI Maximum Average Pressure for the 10mm Auto is 37,500 P.S.I.

10mm AUTO			
Gun	HS PRECISION	Max Length	0.992"
Barrel Length	5"	Trim Length	0.984"
Primer	CCI 300	OAL Max	1.260"
Case	HDY	OAL Min	1.240"

Bullet	START LOADS			MAXIMUM LOADS			Cartridge Length	Comments
	Powder	Grains	Vel.	Powder	Grains	Vel.		
145 (L) FN	No.2	6.8	1136	No.2	7.5	1293	32,200	1.250" Bull-X
	No.5	8.7	1190	No.5	9.7	1352	33,400	
	No.7	10.8	1203	No.7	12.0	1367	33,700	
	No.9	13.5	1251	No.9	15.0	1422	32,500	
165 (L) SWC	No.2	6.4	1082	No.2	7.1	1230	36,000	1.250" Clements
	No.5	7.8	1085	No.5	8.7	1233	31,800	
	No.7	9.9	1120	No.7	11.0	1273	35,500	
	No.9	12.6	1174	No.9	14.0	1334	32,900	
175 (L) SWC	No.2	6.0	1027	No.2	6.7	1167	35,300	1.245" CP
	No.5	7.5	1026	No.5	8.3	1166	31,500	
	No.7	9.4	1055	No.7	10.4	1199	35,200	
	No.9	12.2	1131	No.9	13.6	1265	34,900	
185 (L) FN	No.2	5.9	1000	No.2	6.6	1136	35,900	1.245" Co. Custom
	No.5	7.5	1030	No.5	8.3	1171	36,800	
	No.7	9.2	1032	No.7	10.2	1173	34,500	
	No.9	11.7	1098	No.9	13.0	1248	34,700	

10MM AUTO - ACCURATE POWDERS

10mm AUTO (continued)

Bullet	START LOADS		MAXIMUM LOADS		P.S.I.	Cartridge Length	Comment
	Powder	Grains	Vel.	Powder			
195 (L) FN	No.2	5.2	928	No.2	5.8	1055	1.245" Clements
	No.5	6.6	965	No.5	7.3	1097	
	No.7	6.6	998	No.7	9.5	1134	
	No.9	10.7	1050	No.9	11.9	1193	
205 (L) FN	No.2	4.7	862	No.2	5.2	979	1.250" Clements
	No.5	6.3	935	No.5	7.0	1063	
	No.7	6.4	960	No.7	9.3	1091	
	No.9	10.6	1018	No.9	11.8	1157	
NOS 135 JHP	No.2	8.2	1271	No.2	9.1	1444	1.250"
	No.5	10.3	1323	No.5	11.4	1503	
	No.7	12.2	1299	No.7	13.6	1476	
	No.9	15.8	1326	No.9	17.5	1507	
NOS 150 JHP	No.2	7.6	1182	No.2	8.4	1343	1.245"
	No.5	9.5	1229	No.5	10.6	1397	
	No.7	11.7	1236	No.7	13.0	1405	
	No.9	15.0	1284	No.9	16.7	1459	
HDY 155 JHP	No.2	7.2	1140	No.2	8.0	1296	1.250"
	No.5	9.0	1174	No.5	10.0	1334	
	No.7	11.4	1214	No.7	12.7	1379	
	No.9	14.3	1244	No.9	15.9	1414	
RAN 155 FP	No.2	6.1	1087	No.2	6.8	1236	1.260"
	No.5	8.9	1151	No.5	9.9	1309	
	No.7	11.2	1173	No.7	12.4	1333	
	No.9	13.5	1206	No.9	15.0	1371	
NOS 170 HP	No.2	6.9	1074	No.2	7.7	1220	1.250"
	No.5	8.7	1122	No.5	9.7	1275	
	No.7	10.8	1148	No.7	12.0	1305	
	No.9	13.5	1180	No.9	15.0	1341	
SPR 180 JHP	No.2	6.7	1037	No.2	7.4	1178	1.250"
	No.5	8.3	1069	No.5	9.2	1215	
	No.7	10.3	1084	No.7	11.4	1232	
	No.9	13.1	1135	No.9	14.5	1290	
HDY 180 XTP	No.2	6.1	986	No.2	6.8	1120	1.250"
	No.5	7.8	1053	No.5	8.7	1197	
	No.7	9.6	1041	No.7	10.7	1183	
	No.9	12.2	1093	No.9	13.5	1242	
RAN 180 HP	No.2	5.3	947	No.2	5.9	1077	1.260"
	No.5	7.9	1037	No.5	8.8	1179	
	No.7	9.9	1051	No.7	11.0	1195	
	No.9	12.1	1086	No.9	13.5	1235	
RAN 180 FP	No.2	5.5	967	No.2	6.1	1099	1.260"
	No.5	7.9	1025	No.5	8.6	1165	
	No.7	9.9	1041	No.7	11.0	1184	
	No.9	12.1	1087	No.9	13.5	1236	

10MM AUTO - ALLIANT POWDERS

ALLIANT CONTINUED

POWDER	STARTING LOADS			MAXIMUM LOADS		
	GRS.	VEL.	PRESSURE	GRS.	VEL.	PRESSURE
BULLET: 170 GR. JHP DIA: .400" C.O.L: 1.250"						
BLUE DOT				10.1	1180	33,500 PSI
HERCO				7.5	1145	33,600 PSI
UNIQUE				6.9	1135	34,100 PSI
BULLSEYE				6.2	1135	34,000 PSI
BULLET: 180 GR. JHP DIA: .400" C.O.L: 1.250"						
BLUE DOT				10.4	1220	35,800 PSI
HERCO				7.5	1140	35,800 PSI
POWER PISTOL				8.7	1240	34,900 PSI
UNIQUE				7.0	1125	35,700 PSI
BULLSEYE				6.4	1125	35,900 PSI
BULLET: 190 GR. JFP DIA: .400" C.O.L: 1.250"						
BLUE DOT				10.0	1185	36,000 PSI
HERCO				7.2	1050	35,800 PSI
POWER PISTOL				8.2	1200	35,900 PSI
UNIQUE				6.7	1025	35,500 PSI
BULLSEYE				6.3	1050	35,500 PSI
BULLET: 200 GR. FMJ DIA: .400" C.O.L: 1.260"						
BLUE DOT				8.9	1110	33,800 PSI
HERCO				6.5	965	33,500 PSI
POWER PISTOL				7.7	1145	35,600 PSI
UNIQUE				5.8	940	33,700 PSI
BULLSEYE				5.3	940	33,600 PSI

NEVER EXCEED MAXIMUM LOADS.

Praise The Load



With the Superior Performance of Hodgdon Powders

Superior accuracy can be achieved through reloading with reliable, consistently performing powder. To achieve this level of consistency, the experts at Hodgdon's select only the finest raw materials and give special attention to blending. Rigorous testing of *each* batch of powder further attests to Hodgdon's commitment to quality.

For over 45 years, Hodgdon Powder has been a performance leader among shooters. This explains why more winning shooters competing in benchrest matches use Hodgdon Powder.

Hodgdon encourages every shooter to enjoy the advantages and economy of reloading with the superior performance of Hodgdon Powders.

For more information on reloading & Hodgdon Powders, write:

HODGDON POWDER COMPANY, INC.

P.O. Box 2932, Dept. AB

Shawnee Mission, KS 66201

HODGDON'S INDUSTRY INSIDERS



Russ Rolandson
Sales, Speer Bullets
300 Win. Mag. Caliber
165 gr. Speer Grand Slam
72 Gr. Hodgdon H4350 Powder



**Required
Reading
for
All Reloaders!
*The
Hodgdon
Data Manual***

The Hodgdon Data Manual is the most extensive reloading manual produced by a powder company. **Over 500 pages** of rifle, pistol and shotgun data and includes articles by many well known writers.

- Includes data on Hodgdon, Hercules, Winchester and IMR powders for rifle calibers.
- Complete rifle, lead bullet, shotshell, pistol, military and silhouette data included.
- Complete Pyrodex® section of data and loading information for muzzleloading guns and early cartridge firearms.

THE FAVORITE OF HANDLOADERS SINCE 1946

The most current edition of the Hodgdon Data Manual is available from your local dealer or may be ordered directly from:

Hodgdon Powder Company, Inc.

P.O. Box 2932, Dept. AB
Shawnee Mission, KS 66201

(913) 362-9455

**HODGDON
POWDER CO.**

10MM AUTO - HODGDON POWDERS

10MM AUTO

Whit Collins, John Adams, Irving Stone and Jeff Cooper created the 10mm Auto in the ill-fated Bren Ten back in 1983. Colt gave it life by introducing it in the new Delta Elite version of the famous 1911 Government Model pistol. During 1990, the 10mm Auto was adopted by the FBI. Since that time, the FBI dropped the 10mm in favor of the 40 S&W.

At that, the 10mm Auto is still a superior self defense cartridge for those who can stand the increase in recoil and muzzle blast over the 40 S&W. Universal and HS-6 are excellent choices for this cartridge.

...

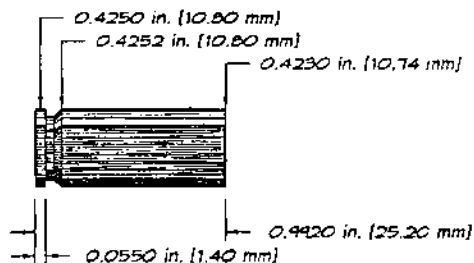

WINCHESTER
5"

WINCHESTER LP

1:16"
987"

10MM AUTO - HODGDON POWDERS

Powder	Starting Loads			Maximum Loads		
	Gr.	Vel.	Pressure	Gr.	Vel.	Pressure

10MM AUTO

Case: WINCHESTER Twist: 1:16"
 Barrel: 5" Trim: .987" Primer: Winchester LP

Bullet: 135 GR. NOS JHP			Dia.: .400"	COL: 1.250"		
HS-6	10.0	1318	31,300 PSI	11.2	1435	36,900 PSI
UNIVERSAL	7.0	1284	30,200 PSI	8.0	1416	36,100 PSI
TITEGROUP	7.2	1362	28,300 PSI	8.0	1459	35,800 PSI

Bullet: 155 GR. HDY XTP			Dia.: .400"	COL: 1.260"		
HS-6	8.8	1095	22,400 PSI	11.0	1350	35,000 PSI
UNIVERSAL	6.5	1135	22,600 PSI	7.5	1279	35,200 PSI
HP-38	5.8	1030	23,000 PSI	7.3	1253	35,700 PSI
TITEGROUP	6.4	1211	26,800 PSI	7.2	1315	35,700 PSI

Bullet: 170 GR. HDY XTP			Dia.: .400"	COL: 1.260"		
HS-6	8.0	1027	23,800 PSI	9.9	1246	35,000 PSI
UNIVERSAL	5.5	989	22,600 PSI	6.7	1187	36,100 PSI
HP-38	4.7	882	21,000 PSI	6.3	1119	35,900 PSI
TITEGROUP	6.0	1148	28,200 PSI	6.6	1232	36,200 PSI

Bullet: 180 GR. SIE JHC			Dia.: .400"	COL: 1.260"		
HS-6	7.4	940	22,000 PSI	9.4	1127	35,800 PSI
UNIVERSAL	5.4	965	22,300 PSI	6.4	1122	32,200 PSI
HP-38	5.2	944	29,700 PSI	5.8	1061	34,900 PSI
TITEGROUP	5.4	1051	27,400 PSI	6.0	1141	34,300 PSI

Bullet: 200 GR. HDY FMJ			Dia.: .400"	COL: 1.260"		
HS-6	7.5	957	26,000 PSI	8.6	1089	35,900 PSI
UNIVERSAL	4.9	846	24,300 PSI	5.9	1015	36,900 PSI
HP-38	4.6	827	24,200 PSI	5.6	1011	35,700 PSI
TITEGROUP	4.8	946	28,900 PSI	5.3	1024	36,100 PSI

NEVER EXCEED MAXIMUM LOADS.

10MM AUTO - IMR POWDERS

IMR		
CASE: REMINGTON	BARREL: 5"	PRIMER: REMINGTON 2 1/2
BULLET: 135 GR. NOS HP		
DIA: .400"		
C.O.L.: 1.250"		
"HI-SKOR" 800-X	14.5	1670 33,100 PSI
SR 4756	10.7	1495 33,000 PSI
SR 7625	9.2	1450 34,000 PSI
BULLET: 155 GR. REM JHP		
DIA: .400"		
C.O.L.: 1.250"		
"HI-SKOR" 800-X	11.6	1475 32,900 PSI
SR 4756	8.5	1310 34,400 PSI
SR 7625	7.8	1275 34,300 PSI

IMR CONTINUED						
POWDER	STARTING LOADS			MAXIMUM LOADS		
	GRS.	VEL.	PRESSURE	GRS.	VEL.	PRESSURE
BULLET: 180 GR. WIN JHP						
DIA: .400"						
C.O.L.: 1.250"						
"HI-SKOR" 800-X	9.7	1320	34,200 PSI			
SR 4756	7.6	1155	34,400 PSI			
SR 7625	7.0	1140	35,100 PSI			
BULLET: 200 GR. HDY. XTP						
DIA: .400"						
C.O.L.: 1.250"						
"HI-SKOR" 800-X	8.4	1190	33,900 PSI			
SR 4756	6.6	1045	35,800 PSI			
SR 7625	6.2	1040	35,700 PSI			

NEVER EXCEED MAXIMUM LOADS.

= NOTICE =

The information presented is based upon results obtained in our ballistics laboratory. Safe loading practices should be observed at all times. Since IMR Powder Company has no control over the circumstances of loading, we assume no liability for the results obtained, and we guarantee only that our powder meets our manufacturing standards.

10MM AUTO - SCOT POWDERS

Barrel Length: 5" // Overall Length Minimum: 1.250"

ROYAL SCOT

<i>Powder Charge</i>	<i>Bullet Weight & Type</i>	<i>Muzzle Velocity</i>
5.9 grains	150 grain Sierra Jacketed HP	1,147 fps
5.8 grains	170 grain Hornady Jacketed HP	1,081 fps
5.6 grains	175 grain Lead Semi-Wadcutter	1,079 fps
5.8 grains	190 grain Sierra Jacketed Flat Point	1,032 fps
5.5 grains	200 grain Hornady FMJ Flat Point	970 fps

PEARL SCOT

<i>Powder Charge</i>	<i>Bullet Weight & Type</i>	<i>Muzzle Velocity</i>
6.4 grains	150 grain Sierra Jacketed HP	1,168 fps
6.3 grains	170 grain Hornady Jacketed HP	1,092 fps
6.2 grains	175 grain Lead Semi-Wadcutter	1,086 fps
6.3 grains	190 grain Sierra Jacketed Flat Point	1,041 fps
6.1 grains	200 grain Hornady FMJ Flat Point	1,032 fps

SOLO 1000

<i>Powder Charge</i>	<i>Bullet Weight & Type</i>	<i>Muzzle Velocity</i>
6.1 grains	150 grain Sierra Jacketed HP	1,157 fps
6.0 grains	170 grain Hornady Jacketed HP	1,086 fps
6.1 grains	175 grain Lead Semi-Wadcutter	1,075 fps
5.8 grains	190 grain Sierra Jacketed Flat Point	1,003 fps
5.4 grains	200 grain Hornady FMJ Flat Point	951 fps

= WARNING =

The Scot Powder Company makes no warranties or guarantees with respect to the safety or suitability of these products or the reloading information contained on these pages, either express or implied. Buyer and user assume any and all risk, responsibility and liability for any and all injury (including death), loss or damage arising from usage!

WINCHESTER Centerfire Rifle Components

When selecting reloading supplies, be sure to look for the following finest quality Winchester components.

Primers

WLR, #8-1/2 - 120, Large Rifle
WLRM, #8-1/2M - 120, Large Rifle Magnum
WSR, #6-1/2 - 116, Small Rifle

BALL POWDER Propellants

680 Powder, 1 Lb. Container
748 Powder, 1 and 8 Lb. Containers
760 Powder, 1 and 8 Lb. Containers

Unprimed Rifle

U218	218 Bee	U300H	300 H&H Mag.
U22H	22 Hornet	U300	300 Savage
U22250	22-250 Rem.	U307	307 Win.
U220S	220 Swift	U308	308 Win.
U223R	223 Rem.	U3220	32-20 Win.
U225	225 Win.	U338	338 Win. Mag.
U243	243 Win.	U348	348 Win.
U6MMR	6mm Rem.	U356	356 Win.
U2520	25-20 Win.	U358	358 Win.
U2506	25-06 Rem.	U375H	375 H&H Mag.
U257P	257 Roberts + P	U375W	375 Win.
U264	264 Win. Mag.	U4440	44-40 Win.
U270	270 Win.	U44M	44 Rem. Mag.
U284	284 Win.	U4570	45-70 Govt.
U7MM	7mm Mauser	U458	458 Win. Mag.
U3006	30-06 Springfield		
U3040	30-40 Krag		
U300WM	300 Win. Mag.		



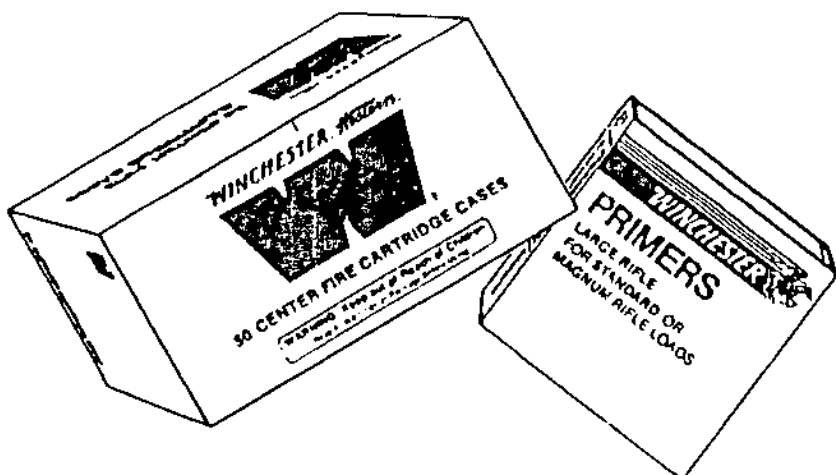

Get Superior Control With Winchester

Reloaders make strenuous demands on their components, and that's the reason why, year after year, more reloaders depend on Winchester.

Winchester is the only ammunition company that makes all of its own components, from raw materials through final product, for the control reloaders demand. Winchester primers are tested for consistent and dependable ignition in extreme temperatures. They are non-corrosive and non-mercuric, and they're carefully controlled for weight and height.

Winchester's patented smokeless, clean-burning BALL POWDER propellants are free-flowing for precise metering and chemically stable for consistent muzzle velocity, and reduced flash and barrel erosion.

Winchester metallic components offer the consistent performance found in factory loads.



10MM AUTO - WINCHESTER POWDERS

WINCHESTER		CASE: WINCHESTER		BARREL: 5"		PRIMER: WINCHESTER LP	
BULLET: 150 GR. WIN JHP		DIA: .400"		C.O.L: 1.260" MAX			
WSF	6.5	1090	24,700 PSI	8.1	1310	35,600 PSI	
231	6.0	1090	29,000 PSI	7.0	1210	35,600 PSI	
WST	5.5	1080	30,200 PSI	7.0	1190	34,000 PSI	
BULLET: 155 GR. WIN JHP		DIA: .400"		C.O.L: 1.260" MAX			
WSF	6.8	1100	23,000 PSI	8.4	1320	35,600 PSI	
231	5.8	1040	23,300 PSI	7.3	1250	35,600 PSI	
WST	5.0	1000	23,100 PSI	8.0	1220	31,900 PSI	
BULLET: 170 GR. WIN JHP		DIA: .400"		C.O.L: 1.260" MAX			
WSF	6.0	1020	24,000 PSI	7.5	1210	35,600 PSI	
231	4.7	880	20,600 PSI	6.3	1120	35,600 PSI	
WST	4.5	940	26,200 PSI	5.5	1020	29,500 PSI	
BULLET: 180 GR. WIN JHP		DIA: .400"		C.O.L: 1.260" MAX			
WSF	5.7	950	25,000 PSI	7.1	1150	35,600 PSI	
231	5.2	950	29,600 PSI	5.8	1050	35,600 PSI	
WST	5.0	950	30,500 PSI	5.5	1010	35,200 PSI	
BULLET: 200 GR. WIN FMJ		DIA: .400"		C.O.L: 1.260" MAX			
WSF	5.2	880	26,200 PSI	6.2	1020	35,600 PSI	
231	4.6	840	24,600 PSI	5.6	1000	35,600 PSI	
WST				4.6	890	35,600 PSI	

NEVER EXCEED MAXIMUM LOADS.

= WARNING =

Winchester makes no warranties express or implied, limited or full; specifically disclaim any and all warranties of fitness for a particular purpose and merchantability; and specifically disclaim any and all liability for consequential damages of any kind whatsoever. Failure to comply with these warnings or to use this data exactly as shown may result in accidents with serious injury and/or death to the shooter and/or bystanders.

10MM AUTO - VIHTAVUORI POWDERS

10mm AUTO

CIP max. dimensions in millimetres, SAAMI in inches)



Country of origin:	Sweden
Year of introduction:	1983
Max. bullet diameter:	10.16 mm (.400")
Max. cartridge length:	32.00 mm (1.260")
Max. shell length:	25.20 mm (.992"), trim to 25.10 mm (.985")
Max. CIP piezo pressure:	250 MPa (36200 psi)

The 10mm AUTO was introduced in 1983 in the Bren Ten pistol. The cartridge was designed following the ideas of noted combat pistol man, Col. Jeff Cooper. The 10mm AUTO factory loads were first offered by Norma, and the newcomer was expected to become a new standard as a service and self defence cartridge. The manufacturer of the Bren-Ten, however, fell into bankruptcy causing the fate of the 10mm AUTO to remain in limbo until 1987, when Colt introduced their Delta Elite pistol in the 10mm AUTO, being followed soon by Smith & Wesson.

The 10mm AUTO has a reputation as a formidable performer. Some people claim the round is OK for hunting, too, but definitely so for self defence and law enforcement, if not already an overkill. Some innovative bullets further enhance the performance of the round, and it is widely considered as an inherently accurate cartridge.

The power of the 10mm AUTO may well have proved to be the cause of its downfall. It is a long cartridge with the C.O.L of 32 mm (1.260") requiring a large frame pistol to accommodate the round. Its impressive power comes with equally impressive recoil. Several of the 10mm AUTO users soon started to require milder loadings for better recoil control as well as for faster recovery time. Smith & Wesson saw the chance and wasted no time in developing a shortened round, the .40 S&W, which met the ballistic parameters required. The .40 S&W has now taken much of the law enforcement market share first estimated for the 10 mm AUTO.

10MM AUTO - VIHTAVUORI POWDERS

10mm AUTO

10 mm Auto is a good number for the reloader. He can enjoy the economy over the relatively high cost of factory ammo; there is a good array of 10 mm bullets available nowadays and the strong case construction allows fairly stiff loadings. Common sense must be observed, though. It is easy to blow up a gun even in 10 mm Auto. All it takes is improper component selection or carelessness in powder charge.

TEST COMPONENTS:

Test barrel: 140 mm (5½"), 1 in 16" twist, manufactured to meet CIP minimum dimensions.

Primers: Large Pistol

Cases: Remington, trim-to length 25.00 mm (.988")

Reloading Data, English Units:

Bullet		Powder		Starting Load		Maximum Load			
Weight (grs)	Type	Mfg.	C.O.L. (in.)	Type	Weight (grs)	Velocity (fps)	Weight (grs)	Velocity (fps)	Pressure (psi)
155	HP-XTP	Homady	1.256	N340	6.7	1165	7.6	1286	max.
				3N37	7.2	1178	8.6	1316	max.
				N350	7.1	1178	8.4	1316	max.
155	FP	Rainier	1.256	N340	7.2	1211	8.0	1322	max.
				N350	8.0	1243	8.9	1378	max.
				3N37	8.2	1224	9.0	1345	max.
180	HP	Speer	1.256	N340	6.0	1024	6.9	1155	max.
				3N37	6.6	1093	7.8	1201	max.
				N350	5.9	1076	7.2	1184	max.
200	FMJ/FP	Homady	1.256	N340	5.0	876	5.7	1014	max.
				3N37	5.9	955	6.8	1073	max.
				N350	5.3	932	6.3	1047	max.
				N105	7.7	1066	8.6	1155	max.

INDICATES MAXIMUM LOAD - USE WITH CAUTION!
LOADS LESS THAN MINIMUM CHARGES SHOWN ARE NOT RECOMMENDED

.40 S&W - HORNADY BULLETS

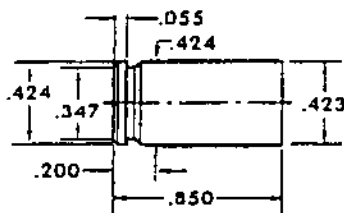

40 S&W

HANDGUN: S & W 4006
BARREL: 4", 1 in 16" Twist
CASE: Hornady
PRIMER: Winchester WSP

BULLET DIAMETER: 0.400"
MAXIMUM C.O.L.: 1.135"
MAX. CASE LENGTH: ... 0.850"
CASE TRIM LENGTH: ... 0.840"

Stopping power is a topic that fuels enough debates to heat Green Bay, Wisconsin every winter. What is it? What do we need? When is enough enough? Why don't we have it? It's not just a topic for the Hot Stove League, but one that gets periodically frenzied when some agency or organization reviews its weaponry.

So the FBI did in the late 1980s. Experimentation with the recent (1983) 10mm Automatic got them interested. Reportedly they were close to reaching caliber/bullet/velocity standards when Winchester and Smith & Wesson came on the scene, formed an almost instantaneous joint venture, and developed and standardized the 40 Smith & Wesson.

The 40 S & W is similar in length to the 9mm Luger and accordingly a 9mm sized pistol was modified for it, producing the Model 4006. With many police organizations following the lead of the army and adopting the 9mm Luger, the 40 S & W entered a very tight race.

The larger bore, greater capacity, and short barrel of the Model 4006 made it powerful and easy to handle—but noisy with a lot of muzzle blast. The 40 S & W quickly eclipsed the 41 Action Express. With improved loads its performance can rival that of the 45 ACP. But whether the 40 S & W will replace the 9mm Luger, the 45 ACP, the 38 Special, or the 357 Magnum, only time will tell.

.40 S&W - HORNADY BULLETS

155 GRAIN BULLETS

SECTIONAL DENSITY: 0.138
DIAMETER: 0.400"

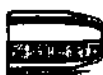

#4000 HP/XTP

B.C.: 0.137 C.O.L.: 1.125"

POWDER	VELOCITY (FPS--feet per second)					
	950	1000	1050	1100	1150	1200
TITEGROUP	4.7 gr.	5.1 gr.	5.4 gr.	5.7 gr.		
CLAYS UNIV.	4.9 gr.	5.3 gr.	5.7 gr.	6.1 gr.	6.5 gr.	
VIHT N-340	5.7 gr.	6.0 gr.	6.4 gr.	6.8 gr.		
POWER PIST.	6.2 gr.	6.7 gr.	7.2 gr.	7.6 gr.	8.1 gr.	8.6 gr.
WIN ACT. PIST.	6.4 gr.	7.0 gr.	7.6 gr.	8.2 gr.	8.8 gr.	
SR 4758	7.1 gr.	7.5 gr.	7.8 gr.	8.1 gr.	8.5 gr.	
800 X	7.1 gr.	7.6 gr.	8.0 gr.	8.4 gr.		
AA No. 5	7.2 gr.	7.6 gr.	8.0 gr.	8.4 gr.		
HS-8	7.2 gr.	7.6 gr.	8.0 gr.	8.4 gr.	8.8 gr.	
Blue Dot	7.4 gr.	7.9 gr.	8.4 gr.	8.9 gr.	9.4 gr.	10.0 gr.
AA No. 7	8.9 gr.	9.5 gr.	10.1 gr.	10.7 gr.	11.3 gr.	

 indicates maximum load • use with caution

.40 S&W - HORNADY BULLETS

180 GRAIN BULLETS

SECTIONAL DENSITY: 0.161
DIAMETER: 0.400"

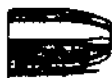

#40040 HP-XTP
B.C.: 0.164 C.O.L.: 1.125"



#400417 FMJ-FP ENC
B.C.: 0.188 C.O.L.: 1.125"

VELOCITY (FPS—feet per second)

POWDER	800	850	900	950	1000	1050
CLAYS UNIV	4.2 gr.	4.6 gr.	4.9 gr.	5.2 gr.		
VIHT N-340	4.4 gr.	4.8 gr.	5.2 gr.	5.5 gr.	5.9 gr.	
POWER PIST	4.6 gr.	5.2 gr.	5.7 gr.	6.2 gr.	6.8 gr.	7.3 gr.
WIN ACT PIST	5.2 gr.	5.7 gr.	6.1 gr.	6.6 gr.	7.1 gr.	
SR 4756	5.6 gr.	5.9 gr.	6.3 gr.	6.6 gr.	7.0 gr.	
800 X	5.0 gr.	5.6 gr.	6.1 gr.	6.7 gr.	7.3 gr.	7.9 gr.
HS-6	5.9 gr.	6.3 gr.	6.7 gr.	7.1 gr.	7.6 gr.	
AA No. 5	5.7 gr.	6.2 gr.	6.7 gr.	7.2 gr.		
Blue Dot	6.3 gr.	6.7 gr.	7.1 gr.	7.4 gr.	7.8 gr.	8.2 gr.
AA No. 7	7.4 gr.	7.9 gr.	8.4 gr.	8.9 gr.	9.4 gr.	

200 GRAIN BULLETS

SECTIONAL DENSITY: 0.179
DIAMETER: 0.400"



#40060 HP-XTP
B.C.: 0.199 C.O.L.: 1.125"

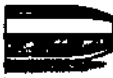

#40077 FMJ-FP ENC
B.C.: 0.182 C.O.L.: 1.125"

VELOCITY (FPS—feet per second)

POWDER	700	750	800	850	900	950
VIHT N-340	4.1 gr.	4.3 gr.	4.6 gr.	4.8 gr.		
POWER PIST	4.6 gr.	5.0 gr.	5.3 gr.	5.7 gr.	6.0 gr.	
SR 4756	4.8 gr.	5.1 gr.	5.4 gr.	5.7 gr.		
WIN ACT PIST	4.6 gr.	5.1 gr.	5.5 gr.	6.0 gr.		
800 X	4.7 gr.	5.1 gr.	5.6 gr.	6.0 gr.	6.5 gr.	6.9 gr.
HS-6	5.3 gr.	5.6 gr.	5.9 gr.	6.3 gr.		
Blue Dot	5.4 gr.	5.7 gr.	6.1 gr.	6.4 gr.	6.7 gr.	7.1 gr.
AA No. 7	6.6 gr.	7.0 gr.	7.5 gr.	7.9 gr.	8.3 gr.	8.8 gr.

indicates maximum load • use with caution

.40 S&W - NOSLER BULLETS

.40 S&W

I remember quite clearly the first round of this stuff I ever saw. My friend Sherry Collins, then the press relations person for S&W, dropped a dummy in my hand just before the 1990 SHOT Show press conference when the cartridge was announced.

Like no other handgun caliber, the .40 S&W was an overnight success.

Today, virtually everyone who makes automatic pistols offers a .40 S&W—or they're about to do so.

The .40 S&W cartridge is a marvel of packaging. It's small enough to go into the double-column magazine of a 9mm-sized pistol but big enough to deliver sufficient energy as to compare favorably with the venerable .45 ACP. The Forty is plainly the personification of compromise. But—and that's a big but—don't fall into the trap of thinking the

.40 S&W is halfway between the two established cartridges. While the .40 S&W is a little less than a .45 ACP, it is assuredly a lot more than a 9mm.

Handloaders are well advised to approach handloading the cartridge with more than usual caution. Very small increases in the powder charge often result in very sharp increases in chamber pressure. It's a good idea to go at your Forty handloading with modest charge increases, watching intently for pressure signs. Be sure your die is adjusted to produce a firm taper crimp. If it isn't, the feeding process can drive the bullet deeper in the case, which alters the case capacity and sends pressures through the roof.

Nosler* makes a wide range of .400-inch JHP bullets suitable for handloading, but my personal favorite remains the 170-grainer which may be loaded to velocities close to 1,000 fps and which produces excellent accuracy in my pet S&W Performance Center Shorty Forty pistol.

We've seen a host of new handgun cartridges developed in the past few years and the .40 S&W is unquestionably the most useful and popular of the crop.



Wiley is Field Editor for Shooting Times and Handgunning magazines.

.40 S&W - NOSLER BULLETS

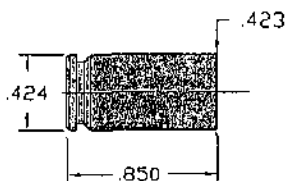
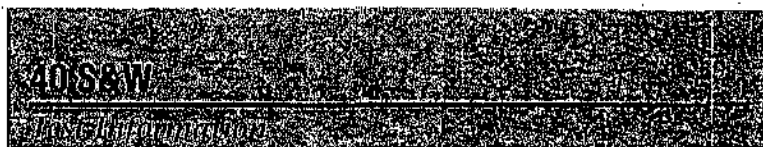

RIFLE:	Barrel: S&W mod 4006
	Length: 4"
	Twist: 1-16"
CASE:	Winchester
PRIMER:	Win. WSP

Comments from the lab

Like most pistol cartridges, the .40 S&W headspaces off of the case mouth. When loading for this cartridge, bell the case mouth just enough to reliably guide the bullet into position, and then taper crimp as Wiley suggested in his intro.

The favorite all-around .40 S&W load in the Ballistics Lab consists of our 135-grain bullet and Blue Dot. All of the standard small pistol primers available give good results with this combination.

The S.A.A.M.I. overall cartridge lengths for the .40 S&W are 1.085" minimum and 1.135" maximum. Seating to anywhere in this range is acceptable as long as the rounds function well in your particular firearm.

.40 S&W - NOSLER BULLETS

Nosler

135 Grain



135 gr.
Hollow Point

*Most Accurate Load Tested

**Compressed Load

Ballistic Coefficient .093

Sectional Density .121

Powder	Charge Weight in Grains	Muzzle Velocity (fps)	Load Density
GREEN DOT	Max. 5.8	1166 fps	46%
	5.3	1047 fps	42%
	4.8*	929 fps	38%
WSL	Max. 5.8*	1110 fps	46%
	5.3	1015 fps	42%
	4.8	919 fps	38%
AA-No. 2	Max. 6.8*	1232 fps	52%
	6.1	1197 fps	48%
	5.6	1162 fps	44%
BULLSEYE	Max. 6.4*	1160 fps	50%
	5.9	1071 fps	46%
	5.4	981 fps	43%
WSI	Max. 6.8*	1108 fps	54%
	6.3	1027 fps	50%
	5.8	945 fps	46%
WSF	Max. 7.8*	1242 fps	61%
	7.3	1157 fps	57%
	6.8	1072 fps	54%
UNIQUE	Max. 7.2*	1125 fps	57%
	6.7	1042 fps	53%
	6.2	958 fps	49%
AA-No. 5	Max. 9.0*	1117 fps	71%
	8.5	1091 fps	67%
	8.0	1065 fps	63%
HS 7	Max. 10.5*	1162 fps	83%
	10.0	1106 fps	79%
	9.5	1050 fps	75%
AA-No. 7	Max. 11.9	1224 fps	94%
	11.4	1190 fps	90%
	10.9*	1156 fps	86%
BLUE DOT (Most Accurate Powder Tested)	Max. 12.0*	1320 fps	94%
	11.5	1265 fps	91%
	11.0	1210 fps	87%

Use Maximum Loads with Caution

.40 S&W - NOSLER BULLETS

Nosler

150 Grain



150 gr.
Hollow Point

*Most Accurate Load Tested
**Compressed Load

Ballistic Coefficient .106
Sectional Density .134

Powder	Charge Weight in Grains	Muzzle Velocity (fps)	Load Density
AA-No. 2	Max. 6.4	1118 fps	57%
	5.9	1070 fps	52%
	5.4*	1022 fps	48%
W 231	Max. 6.5*	1143 fps	58%
	6.0	1081 fps	53%
	5.5	1018 fps	49%
HP 38	Max. 6.6*	1107 fps	59%
	6.1	1022 fps	54%
	5.6	937 fps	50%
WAP	Max. 7.5	1136 fps	67%
	7.0	1046 fps	62%
	6.5*	955 fps	58%
POWER PISTOL	Max. 8.0	1170 fps	71%
	7.5	1102 fps	67%
	7.0*	1035 fps	62%
AA-No. 5 (Most Accurate Powder Tested)	Max. 8.7*	1133 fps	77%
	8.2	1031 fps	73%
	7.7	988 fps	68%
HS 6	Max. 9.2*	1137 fps	82%
	8.7	1075 fps	77%
	8.2	1013 fps	73%
AA-No. 7	Max. 10.5	1083 fps	93%
	10.0	1019 fps	89%
	9.5*	955 fps	84%

Use Maximum Loads with Caution

.40 S&W - NOSLER BULLETS

Nosler

170 Grain



170 gr.
Hollow Point

*Most Accurate Load Tested
**Compressed Load

Ballistic Coefficient .137
Sectional Density .152

Powder	Charge Weight in Grains	Muzzle Velocity (fps)	Load Density
WSL. (Most Accurate Powder Tested)	Max. 5.1*	934 fps	49%
	4.6	920 fps	44%
	4.1	857 fps	39%
W 231	Max. 5.3*	976 fps	50%
	4.8	911 fps	46%
	4.3	846 fps	41%
UNIQUE	Max. 6.8*	1086 fps	65%
	6.3	1020 fps	60%
	5.8	953 fps	55%
POWER PISTOL	Max. 7.0	1056 fps	67%
	6.5	991 fps	62%
	6.0*	925 fps	57%
3N37	Max. 7.3	1099 fps	70%
	6.8	1041 fps	64%
	6.3*	982 fps	60%
AA-No. 5	Max. 7.8*	1036 fps	74%
	7.3	987 fps	70%
	6.8	938 fps	65%
HS 6	Max. 8.0	986 fps	76%
	7.5	885 fps	71%
	7.0*	784 fps	67%
AA-No. 7	Max. 9.3*	1046 fps	89%
	8.8	1001 fps	84%
	8.3	956 fps	79%

Use Maximum Loads with Caution

.40 S&W - NOSLER BULLETS

Nosler

180 Grain



180 gr.
Hollow Point

*Most Accurate Load Tested

**Compressed Load

Ballistic Coefficient .147

Sectional Density .161

Powder	Charge Weight in Grains	Muzzle Velocity (fps)	Load Density
BULLSEYE	Max. 4.8*	901 fps	48%
	4.3	797 fps	43%
	3.8	694 fps	38%
GREEN DOT	Max. 4.9*	922 fps	49%
	4.4	825 fps	44%
	3.9	727 fps	39%
AA-No. 2	Max. 5.3	955 fps	53%
	4.8	898 fps	48%
	4.3*	842 fps	43%
WST	Max. 4.8*	860 fps	48%
	4.3	768 fps	43%
	3.8	675 fps	38%
WSE <i>(Most Accurate Powder Tested)</i>	Max. 5.9*	981 fps	59%
	5.4	897 fps	54%
	4.9	813 fps	49%
AA-No. 5	Max. 7.2*	971 fps	72%
	6.7	936 fps	67%
	6.2	901 fps	62%
HS 7	Max. 7.9	918 fps	79%
	7.4	861 fps	74%
	6.9*	804 fps	69%
AA-No. 7	Max. 8.8*	944 fps	88%
	8.3	914 fps	83%
	7.8	884 fps	78%

Use Maximum Loads with Caution

.40 S&W - SIERRA BULLETS

40 S&W

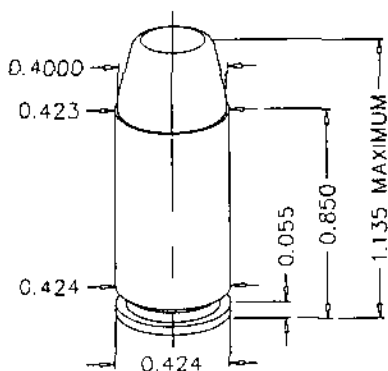

Test Specifications/ Components

Firearm Used: Para Ordnance P-16

Barrel Length: 5"

Twist: 1 x 16"

Case: Starline

Trim-to Length: 0.840"

Primer: Winchester WSP

Remarks:

Few cartridges in recent memory have enjoyed such immediate acceptance as the 40 Smith & Wesson. Introduced in 1990, the 40 S&W apparently hit upon the ideal combination of gun size, mild recoil, high magazine capacity and reliable stopping power.

Duplicating the performance of the

"10mm Lite" loads adopted by the FBI, Smith & Wesson's engineers sought to produce a cartridge short enough to be chambered in their smaller 9mm frame. The combination was a success, and the California Highway Patrol as well as several other large law enforcement agencies soon adopted the 40 S&W.

Loading the 40 S&W is no more difficult than loading for any other rimless case for auto pistols. Fast-burning powders, such as 231 and Accurate Arms #2, will give good results for light target-type loads. Medium burning powders, such as Unique and HS-6, will perform better for the heavier loads. Like the 45 ACP and the 9mm Luger, the 40 should be given a moderate taper crimp to ensure reliable feeding. Although the 10mm and 40 S&W have the same head dimensions, 40 S&W cases cannot be made by trimming 10mm cases to length. Cases for the 40 have a different internal taper, because of their shorter length, and are designed to use a small primer.

We have found the 40 S&W to be an accurate cartridge, but not quite capable of producing the incredible groups so frequently seen in the 10mm Auto. Intended as a service cartridge from its inception, it has more than acceptable accuracy for any law enforcement or self-defense task. While we have seen some IPSC/USPSA handguns chambered for the 40 S&W, it doesn't seem to have made much impact in competitive circles. This may change as the tactical and/or stock classes expand. In the meantime, the 40 S&W will have to settle for being the most successful new duty cartridge to come down the pike.

.40 S&W - SIERRA BULLETS

40 S&W *continued*

#8425 .400" 135 gr. JHP
C.O.A.L. 1.125"



Powder/Velocity--	950	1000	1050	1100	1150	1200	1250	1300	1350
AA-No. 2		5.1	5.5	5.9	6.3	6.6	7.0	7.4	
Clays		4.0	4.4	4.8	5.3	5.7	6.1	6.5	
Viht N320	5.0	5.3	5.5	5.8	6.1	6.4	6.6	6.9	
WST	6.4	6.6	6.8	7.0	7.2	7.4	7.6	7.8	
231		5.2	5.5	5.9	6.2	6.5	6.9	7.2	
ZIP		5.2	5.5	5.8	6.1	6.4	6.7	7.0	
Viht N330	5.6	5.9	6.1	6.4	6.6	6.9	7.1	7.4	
AA-No. 5		7.3	7.7	8.1	8.5	8.9	9.3	9.7	
Unique		5.7	6.1	6.5	6.9	7.3	7.7	8.1	8.5
Univ. Clays	5.6	5.9	6.2	6.4	6.7	7.0	7.3	7.5	7.8
SR7625	6.4	6.7	7.0	7.3	7.6	7.9	8.2	8.5	8.8
HS-6	7.2	7.5	7.9	8.2	8.5	8.8	9.2	9.5	
Silhouette	7.0	7.2	7.5	7.7	8.0	8.2	8.4	8.7	8.9
Viht N340	6.4	6.6	6.8	7.0	7.2	7.4	7.6	7.8	8.0
Herco	6.5	6.9	7.3	7.8	8.2	8.6	9.0		
WSF		6.0	6.4	6.7	7.1	7.5	7.9	8.2	8.6
SR4756	7.2	7.6	7.9	8.3	8.6	9.0	9.3	9.7	
Viht 3N37	7.3	7.6	7.8	8.1	8.4	8.6	8.9	9.1	9.4
AA-No. 7	8.6	9.0	9.4	9.8	10.1	10.5	10.9		
True Blue	6.7	7.1	7.5	7.9	8.2	8.6	9.0	9.4	
Viht N350	6.9	7.2	7.4	7.7	7.9	8.2	8.4	8.7	8.9
Energy/ft.lbs.	270	299	330	362	396	431	468	506	546

	Powder	Grains	Velocity	Ft. lbs.
Accuracy Load	AA-No. 5	8.9	1200	431
Hunting Load	Viht N340	7.8	1300	506

INDICATES MAXIMUM LOAD - USE CAUTION
LOADS LESS THAN MINIMUM CHARGES SHOWN ARE NOT RECOMMENDED.

.40 S&W - SIERRA BULLETS

40 S&W continued

#8430 .400" 150 gr. JHP
C.O.A.L. 1.125"



Powder/Velocity →	900	950	1000	1050	1100	1150	1200	1250
AA-No. 2	4.9	5.2	5.6	5.9	6.2			
Clays	3.6	4.0	4.4	4.7	5.1	5.5		
Viht N320	4.8	5.0	5.2	5.4	5.6	5.8		
WST	4.4	4.8	5.2	5.6	6.0	6.4		
231	4.8	5.1	5.3	5.6	5.8	6.1		
ZIP	4.7	5.0	5.3	5.6	5.8	6.1	6.4	
Viht N330	5.3	5.6	5.8	6.1	6.3	6.6		
AA-No. 5	7.0	7.3	7.6	7.8	8.1	8.4		
Unique	5.6	5.9	6.2	6.6	6.9	7.2	7.5	
Univ. Clays	4.6	4.9	5.2	5.5	5.8	6.1	6.4	6.7
SR7625	5.7	6.0	6.3	6.6	7.0	7.3	7.6	7.9
HS-6	6.9	7.2	7.4	7.7	8.0	8.2	8.5	
Silhouette		6.4	6.7	6.9	7.2	7.5	7.7	8.0
Viht N340	5.3	5.6	5.8	6.1	6.4	6.7	6.9	7.2
Herco	5.7	6.1	6.5	6.9	7.2	7.6	8.0	
WSF	5.6	5.9	6.2	6.5	6.9	7.2	7.5	7.8
SR4756	6.3	6.7	7.0	7.4	7.8	8.1	8.5	
Viht 3N37	6.5	6.8	7.1	7.5	7.8	8.1	8.4	
AA-No. 7	8.1	8.5	8.8	9.2	9.5	9.9		
True Blue	6.2	6.6	7.0	7.4	7.7	8.1	8.5	
Viht N350	6.0	6.3	6.6	6.9	7.1	7.4	7.7	8.0
Energy/ft.lbs.	269	300	333	367	403	440	479	520

	Powder	Grains	Velocity	Ft. lbs.
Accuracy Load	Viht N320	5.6	1100	403
Hunting Load	Univ. Clays	6.4	1200	479

INDICATES MAXIMUM LOAD - USE CAUTION
LOADS LESS THAN MINIMUM CHARGES SHOWN ARE NOT RECOMMENDED.

.40 S&W - SIERRA BULLETS

40 S&W continued

#8445 .400" 165 gr. JHP
C.O.A.L. 1.125"



Powder/Velocity--	850	900	950	1000	1050	1100	1150
AA-No. 2	4.4	4.8	5.3	5.7			
Clays	3.4	3.9	4.3	4.8	5.2		
Viht N320	4.2	4.5	4.8	5.1	5.4		
WST	4.3	4.7	5.2	5.6	6.0		
231		4.6	5.0	5.3	5.7		
ZIP	4.5	4.8	5.1	5.3	5.6	5.9	
Viht N330	5.0	5.2	5.5	5.7	6.0	6.2	
AA-No. 5	6.6	6.9	7.2	7.5	7.8		
Unique	5.2	5.5	5.8	6.1	6.4	6.7	7.0
Univ. Clays	4.6	4.9	5.2	5.5	5.8	6.1	6.4
SR7625	5.4	5.7	6.0	6.4	6.7	7.0	7.3
HS-6	6.4	6.7	7.0	7.3	7.6	7.9	
Silhouette	5.9	6.2	6.5	6.8	7.0	7.3	7.6
Viht N340	5.3	5.6	5.8	6.1	6.3	6.6	6.8
Herco	5.6	5.9	6.3	6.6	7.0	7.3	
WSF	5.5	5.8	6.1	6.4	6.6	6.9	7.2
SR4756	6.2	6.5	6.8	7.1	7.4	7.7	
Viht 3N37	6.1	6.4	6.7	7.1	7.4	7.7	8.0
AA-No. 7	7.8	8.2	8.5	8.9	9.2	9.6	
True Blue	6.0	6.4	6.8	7.2	7.6	8.0	
Viht N350	5.7	6.0	6.3	6.6	6.9	7.2	7.5
Viht 3N38		7.4	7.6	7.8	8.0	8.2	8.4
Energy/ft.lbs.	264	296	330	366	404	443	484

	Powder	Grains	Velocity	Ft. lbs.
Accuracy Load	Clays	5.2	1050	404
Hunting Load	Univ. Clays	6.1	1100	443

INDICATES MAXIMUM LOAD - USE CAUTION
LOADS LESS THAN MINIMUM CHARGES SHOWN ARE NOT RECOMMENDED.

.40 S&W - SIERRA BULLETS

40 S&W continued

#8460 .400" 180 gr JHP
C.O.A.L. 1.125"



Powder/Velocity →	800	850	900	950	1000	1050	1100
AA-No. 2	4.1	4.6	5.0	5.5			
Clays	3.4	3.8	4.2	4.6	5.0		
Vihl N320		4.1	4.5	4.8	5.2		
WST	3.9	4.4	4.8	5.3	5.7		
231	4.4	4.7	5.0	5.3	5.6		
ZIP		4.5	4.8	5.1	5.4	5.7	
Vihl N330	4.4	4.7	5.0	5.3	5.6	5.9	
AA-No. 5	6.3	6.6	6.9	7.2	7.5		
Unique	4.6	4.9	5.3	5.6	6.0	6.3	
Univ. Clays		4.2	4.6	4.9	5.3	5.6	6.0
Power Pistol	5.1	5.5	5.8	6.2	6.5	6.9	
SR7625	4.8	5.2	5.5	5.9	6.2	6.6	
HS-6		6.2	6.6	6.9	7.3	7.6	
Silhouette		5.5	5.9	6.3	6.6	7.0	7.4
Vihl N340		4.7	5.0	5.3	5.7	6.0	6.3
Herco		5.2	5.5	5.9	6.2	6.5	
WSF	5.0	5.3	5.6	6.0	6.3	6.6	
SR4756	5.5	5.8	6.2	6.5	6.9	7.2	
Vihl 3N37		6.1	6.4	6.7	6.9	7.2	7.5
AA-No. 7		7.6	8.0	8.4	8.8	9.2	
True Blue	5.8	6.1	6.5	6.8	7.2	7.5	
Vihl N350		5.4	5.7	6.0	6.4	6.7	7.0
Vihl 3N38		7.0	7.2	7.5	7.7	8.0	8.2
Energy/ft.lbs.	255	288	323	360	399	440	483
		Powder	Grains	Velocity	Ft. lbs.		
Accuracy Load		Clays	4.6	950	360		
Hunting Load		Vihl N320	5.2	1000	399		

INDICATES MAXIMUM LOAD - USE CAUTION
LOADS LESS THAN MINIMUM CHARGES SHOWN ARE NOT RECOMMENDED.

.40 S&W - SIERRA BULLETS

40 S&W continued

#8480 .400" 190 gr FPJ Match
C.O.A.L. 1.125"



Powder/Velocity--	750	800	850	900	950	1000	1050
AA-No. 2	4.1	4.5	4.9	5.3			
Clays	3.2	3.6	4.0	4.3	4.7		
Viht N320	4.2	4.4	4.6	4.8	5.0		
WST	3.8	4.2	4.6	5.0			
231	4.3	4.6	4.9	5.2	5.5		
ZIP	4.0	4.3	4.6	4.9	5.2	5.5	
Viht N330	4.3	4.6	4.9	5.2	5.5	5.8	
AA-No. 5	6.1	6.4	6.7	7.0	7.3		
Unique	4.7	5.0	5.3	5.6	5.9	6.2	
Univ. Clays		4.2	4.6	4.9	5.3	5.6	
Power Pistol	4.6	5.0	5.4	5.8	6.2	6.6	
SR7625	4.9	5.2	5.5	5.8	6.1	6.4	
HS-6	5.8	6.1	6.4	6.7	7.0	7.3	
Silhouette	5.3	5.6	5.9	6.2	6.5	6.8	7.1
Viht N340	4.5	4.8	5.1	5.4	5.7	6.0	
Herco	4.9	5.2	5.5	5.8	6.1	6.4	
WSF	4.8	5.1	5.4	5.7	5.9	6.2	6.5
SR4756	5.5	5.8	6.1	6.4	6.7	7.0	
Viht 3N37	5.7	6.0	6.3	6.6	6.9	7.2	
AA-No. 7			7.7	8.1	8.5	8.9	
True Blue		5.9	6.3	6.6	7.0	7.3	
Viht N350	5.2	5.5	5.8	6.1	6.4	6.7	7.0
Viht 3N38			6.9	7.2	7.5	7.8	8.1
Energy/ft.lbs.	237	270	304	341	380	421	465

	Powder	Grains	Velocity	Ft. lbs.
Accuracy Load	WSF	5.9	950	380
Hunting Load	HS-6	7.3	1000	421

INDICATES MAXIMUM LOAD - USE CAUTION
LOADS LESS THAN MINIMUM CHARGES SHOWN ARE NOT RECOMMENDED.

.40 S & W - SPEER BULLETS

The 40 S&W is a relative newcomer to the semi-auto pistol arena. Developed jointly by Smith & Wesson and Winchester, the cartridge was announced in January of 1990.

The 40 S&W resulted from law enforcement interest in the potent 10mm Auto cartridge. Many police administrators considered full-power 10mm ammo too powerful for typical police applications. To remedy this, the 10mm was loaded lighter to fire 180 grain bullets at 980 feet/sec. This modification reduced recoil and gave excellent ballistic performance; even so, the large 10mm pistols proved too bulky for plain-clothes officers or those with small hands.

The 40 S&W concept was to put a 10mm (40 caliber) cartridge on the smaller 9mm frame. To do this, Winchester developed a shortened 10mm loaded to the law enforcement velocity specification (980 feet/sec). Operating pressures and loaded cartridge length of the new cartridge are essentially the same as the 9mm Luger. Thus a cartridge having energy levels approaching the 45 Auto cartridge was available in a package not much larger than standard 9mm pistols.

The new combo was an immediate success. All major ammunition makers now load 40 S&W and reloading dies and components are selling extremely well. Factory ammunition is available with 155, 165 and 180 grain bullets. Speer offers three weights in the Gold Dot hollow point for hunting and defense, and in its TMJ line for plinking and target practice.

Gunwriter Charles Petty has done extensive accuracy testing with the 40 S&W and found that quick-burning powders seldom give top accuracy unless downloaded. Handgun propellants in the middle range of burning rates performed

best, and our tests here at Speer substantiate Petty's findings, especially with the Gold Dot bullets.

Original 165 grain loads were intended as reduced-pressure loads for law enforcement. More recently the trend is to load the 165 grain bullet to full pressures. The loads here reflects that trend. However, several start loads shown here for this bullet were chosen to meet the 980 ft/sec velocity level of the older "40 Lite" loads. As such, they are quite useful for accuracy loading and to reduce recoil in the newer 40 caliber subcompacts.

We are often asked for loading data for the Speer 200 grain TMJ in the 40 S&W. When seated to the proper cartridge overall length, the bullet heel is so deep in the case that sidewall bulges often develop with resulting failures to feed or chamber. Velocities are also quite low, so we don't recommend this bullet for the 40 S&W.

Reloading the 40 S&W is simple, straight-forward and much like the 45 Auto. As with other semi-auto cartridges, taper crimping is recommended. Note that the 40 S&W uses small pistol primers compared to the 10mm which uses large primers. The loads shown do not exceed the industry pressure maximum of 35,000 psi.

.40 S & W - SPEER BULLETS

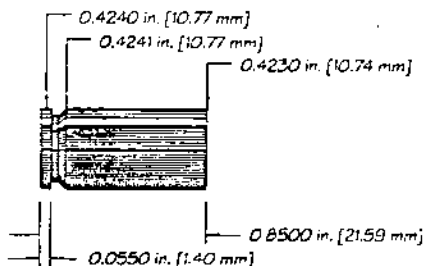

Max. Case Length: 0.850" Test Firearm: Smith & Wesson Model 4006
 Trim-to Length: 0.840" Case: Speer
 Max. Cart. Length: 1.135" Primers: CCI 500
 RCBS Shellholder: #27
 Barrel Length: 4"
 Twist: 1-16"



.400" Dia.
155 Grain

Sect. Density .138

	40/10mm TMJ	40/10mm GD-HP						
Ballistic Coefficient	0.125	0.123						
C.O.L. Tested At	1.120"	1.120"						
Speer Part No.	4399	4400						
Powder	Wt. Grs.	Mzi.Vel.	Powder	Wt. Grs.	Mzi.Vel.	Powder	Wt. Grs.	Mzi.Vel.
	11.0	1221	AA	8.7	1116		6.5	1038
Blue Dot	10.0	1113	#5	7.9	956	231	5.8	867
	9.0	1213		7.5	1090		9.0	1033
Power Pistol	8.0	1112	WSF	6.7	981	HS-6	7.3	786
	8.0	1207	AA	11.0	1089		6.0	1023
Unique	7.2	1048	#7	10.0	984	Bullseye	5.4	905
	7.0	1159	Vht.	7.7	1082	American	5.6	1001
H. Universal	6.2	995	N350	6.9	871	Select	5.0	931
	6.2	1144		10.0	1051	AA	6.5	956
Tite-Group	5.4	1011	HS-7	9.0	921	#2 Impr.	5.8	840

Notes: Bold print denotes maximum loads. They should be used with caution.

.40 S & W - SPEER BULLETS

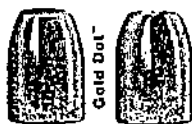

.400" Dia.

165 Grain

Sect. Density .147

	40/10mm TMJ	40/10mm GD-HP				
Ballistic Coefficient	0.135	0.138				
C.O.L. Tested At	1.120"	1.120"				
Speer Part No.	4410	4397				

Powder	Wt. Grs.	Mzl. Vel.	Powder	Wt. Grs.	Mzl. Vel.	Powder	Wt. Grs.	Mzl. Vel.
Viht. N350	7.5	1106	H.	6.2	1074	AA	10.5	1041
	6.7†	989	Universal	5.7†	999	#7	9.6†	951
HS-7	9.8	1085	AA	8.5	1067	Tite-Group	5.4	1035
	9.0	1008	#5	7.6	916		5.0†	957
WSF	6.8	1082		7.2	1064		6.3	1031
	6.2	1007	Unique	6.2	882	231	5.8†	955
Power Pistol	7.8	1081		8.5	1060		5.8	1022
	7.0†	978	HS-6	8.0	1012	Bullseye	5.3†	949

NOTE: Loads marked with "†" approximate 40 S&W 165 grain law enforcement version ("40 Lite").

SAFETY NOTICE

Some pistols chambered for the .40 S&W cartridge may not provide complete support of the case head. If this condition exists, normal pressure loads such as those shown here can cause the case wall to bulge or rupture at the unsupported point. Contact your firearm manufacturer to determine if your pistol completely supports the case head, or ask a gunsmith to inspect your pistol before using it with ANY ammunition. It is the gun owner's responsibility to know his firearm and its capabilities and limitations.

.40 S&W - LYMAN BULLETS

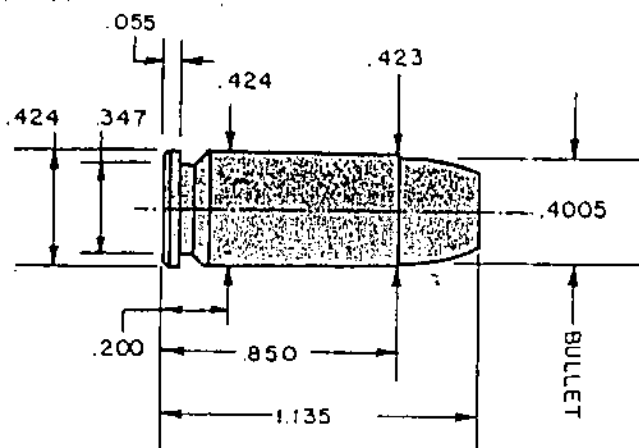

COMMENTS:

The 40 S&W has quickly become a very popular cartridge as it is a good choice between the 9mm and 45 ACP. It has lighter recoil and greater magazine capacity than the 45 ACP and is more powerful than the 9mm. Accuracy in most handguns is superb, especially with Hercules Bullseye, Winchester 231 and Accurate Arms No. 5.

This cartridge headspaces from the mouth and therefore case trimming must be uniform and accurate. Do not reduce cases below the trim-to length. Additionally do not roll crimp bullets as this will prevent the case from properly headspacing on its mouth. A modest taper crimp may be employed if found necessary.

It is important not to seat bullets to a shorter length than listed in any handgun cartridge; but especially so in this one. Pressures can be raised dramatically with deep seating.

TEST COMPONENTS:

Cases	Winchester
Trim-to Length847"
Primers	Winchester 1½-108
Primer Size	Small Pistol
Lyman Shell Holder	No. 15
Cast Bullets Used	(Sized to .401" dia.)
	#401043, 175 gr.
	#401638, 175 gr.
	#401633, 200 gr.

TEST SPECIFICATIONS: (Velocity & Pressure)

Firearm Used	Universal Receiver
Barrel Length	4"
Twist	1-16"
Groove Dia.401"

.40 S&W - LYMAN BULLETS



#401043

175 gr., [#2 Alloy] 1.125" OAL

POWDER	Sugg.			Max.		
	Starting Grains	Velocity fps	Pressure C.U.P.	Load Grains	Velocity fps	Pressure C.U.P.
Unique	4.8	911	15,900	5.8	1023	23,300
Blue Dot	7.3	897	17,900	9.0	1123	23,500
231	4.3	863	15,400	5.8	977	22,500
WST	4.8	944	18,300	6.3	1094	22,900
WSL	4.1	891	17,400	4.9	1049	22,700
800X	5.6	853	16,500	7.4	974	22,400
HS-6	7.0	940	17,000	8.2	1047	23,300
AA 5	6.1	903	19,300	6.9	1066	23,000
Bullseye	4.2	665	17,100	5.1	812	22,000

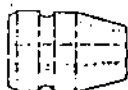

#401638

175 gr., [#2 Alloy] 1.100" OAL

POWDER	Sugg.			Max.		
	Starting Grains	Velocity fps	Pressure C.U.P.	Load Grains	Velocity fps	Pressure C.U.P.
Unique	4.7	898	18,600	5.8	971	23,200
Blue Dot	6.9	979	18,100	8.6	1059	23,200
231	4.3	796	16,000	5.8	970	22,700
WSL	4.3	957	18,300	5.1	992	23,000
800X	5.8	878	17,000	7.6	996	22,900
HS-6	7.0	976	18,600	8.4	1129	22,800
AA 5	6.0	844	18,600	6.9	1047	22,600
Bullseye	4.0	654	16,900	5.0	842	23,100
Clays	3.3	641	17,800	4.2	800	22,500

Note: Loads shown in shaded panels are maximum.

.40 S&W - LYMAN BULLETS



#401633

200 gr., (#2 Alloy) 1.115" OAL

POWDER	Sugg. Starting Grains	Velocity fps	Pressure C.U.P.	Max. Load Grains	Velocity fps	Pressure C.U.P.
Unique	4.3	902	18,900	5.3	953	23,100
231	4.0	867	17,300	5.5	945	22,600
WSF	4.7	909	18,700	5.6	1043	23,400
800X	4.9	814	17,500	6.4	992	22,500
HS-6	5.6	902	18,100	6.9	996	23,100
AA 5	4.6	878	17,000	5.3	990	22,600

Note: Loads shown in shaded panels are maximum.

.40 S & W/.41 AE - ACCURATE POWDERS

.40 SMITH & WESSON/.41 AE

Introduced in 1990, this cartridge was developed primarily for the law enforcement market. Guns chambered for the .40 S&W combine high-capacity magazines with acceptable stopping power. It is slightly less powerful than the 10mm Auto — which reduces the probability of over-penetration — but is considerably easier to control during rapid fire.

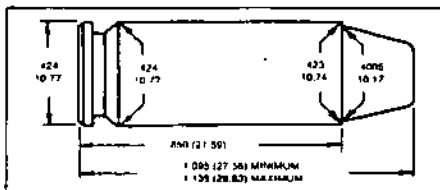

As a result of testing to optimize terminal ballistics on the 10mm Auto, the FBI adopted a reduced power loading. Smith & Wesson subsequently offered a cartridge with a similar power level chambered in a pistol with a high-capacity magazine.

In an amazingly short period, the .40 S&W has gained wide acceptance throughout the U.S. in the law enforcement field.

The .40 S&W is an easy cartridge to load and gives excellent performance with the complete line of Accurate's handgun propellants.

This data should also prove suitable for loading the .41 Action Express. The .41 Action Express has a rebated rim case permitting the owner of a 9mm handgun to change calibers by merely replacing the barrel and magazine. Its performance is nearly identical to that of the .40 S&W.

The SAAMI Maximum Average Pressure for the .40 S&W is 35,000 P.S.I.

.40 SMITH & WESSON / .41 AE				
Gun	HS PRECISION	Max Length	0.850"	
Barrel Length	4"	Trim Length	0.840"	
Primer	CCI 500	OAL Max	1.135"	
Case	HDY	OAL Min	1.095"	

Bullet	START LOADS			MAXIMUM LOADS			Cartridge Length or Comment (in.)
	Powder	Grains	Vel. (ft.)	Powder	Grains	Vel. (ft.)	
145 (L) FN	No.2	5.9	1016	No.2	6.6	1155	1.115" Bull-X
	No.5	7.2	1038	No.5	8.0	1179	
	No.7	9.0	1030	No.7	10.0	1171	
	No.9	10.8	988	No.9	12.0	1123	
155 (L) SWC	No.2	5.7	982	No.2	6.3	1116	1.130" Master Cast Major Major
	No.5	6.8	1019	No.5	7.5	1158	
	No.7	8.7	1008	No.7	9.7	1146	
	No.9	10.8	1005	No.9	12.0	1142	

.40 S & W/.41 AE - ACCURATE POWDERS

Bullet No.	START LOADS			MAXIMUM LOADS			P.S.L.	Cartridge Length	Comment
	Powder	Grains	Vel.	Powder	Grains	Vel.			
175 (L) SWC	No.2	4.8	858	No.2	5.3	975	34,200	1.115"	CP Major
	No.5	5.5	868	No.5	6.1	986	35,000		
	No.7	7.6	892	No.7	8.4	1014	35,000		
	No.9	9.2	878	No.9	10.2	998	34,900		
185 (L) FN	No.2	4.6	829	No.2	5.1	942	33,000	1.120"	Co. Custom Major Major
	No.5	5.4	858	No.5	6.0	975	35,000		
	No.7	7.4	871	No.7	8.2	990	35,000		
	No.9	8.7	841	No.9	9.7	956	33,500		
195 (L) FN	No.2	4.1	774	No.2	4.6	880	34,900	1.110"	Clements Major Major
	No.5	4.8	798	No.5	5.3	907	35,000		
	No.7	6.1	777	No.7	6.8	883	34,800		
	No.9	8.1	812	No.9	9.0	923	35,000		
205 (L) FN	No.2	3.9	737	No.2	4.3	838	32,400	1.110"	Clements Major
	No.5	4.5	736	No.5	5.0	836	32,600		
	No.7	5.9	744	No.7	6.6	845	33,700		
	No.9	7.8	774	No.9	8.7	880	35,000		
SFB 125 FP Frangible	No.2	5.1	1022	No.2	5.7	1162	34,700	1.160"	
	No.5	6.0	863	No.5	6.7	981	32,900		
	No.7	9.1	1041	No.7	10.1	1184	35,300		
SFB 130 SWC Frangible	S1250	4.7	949	S1250	5.2	1079	33,100	1.125"	
	No.2	4.3	887	No.2	4.8	1008	33,300		
	No.5	6.3	938	No.5	7.0	1066	33,900		
	No.7	8.3	939	No.7	9.2	1068	33,700		
NOS 135 JHP	No.2	6.8	1097	No.2	7.6	1247	34,700	1.125"	
	No.5	8.4	1114	No.5	9.3	1266	34,900		
	No.7	10.1	1089	No.7	11.2	1237	33,900		
	No.9	N/R	N/R	No.9	N/R	N/R	N/R		
NOS 150 JHP	No.2	6.3	1016	No.2	7.0	1155	34,200	1.120"	Major
	No.5	7.5	1030	No.5	8.3	1170	35,000		
	No.7	9.2	1060	No.7	10.2	1136	34,300		
	No.9	N/R	N/R	No.9	N/R	N/R	N/R		
RAN 155 FP	No.2	5.6	968	No.2	6.2	1100	35,000	1.125"	Major Compressed
	No.5	6.9	963	No.5	7.7	1095	32,100		
	No.7	9.3	998	No.7	10.3	1135	34,300		
	No.9	11.7	993	No.9	13.0	1129	28,700		
NOS 170 JHP	No.2	5.6	916	No.2	6.2	1041	35,000	1.125"	Major Major Major Compressed
	No.5	6.5	911	No.5	7.2	1035	34,000		
	No.7	8.4	923	No.7	9.3	1049	34,400		
	No.9	10.2	902	No.9	11.3	1025	30,800		
SPR 180 JHP	No.2	5.1	840	No.2	5.7	955	33,800	1.125"	Major Major Major
	No.5	6.3	873	No.5	7.0	992	35,000		
	No.7	7.9	866	No.7	8.8	984	34,400		
	No.9	9.9	875	No.9	11.0	994	32,100		

.40 S & W - ALLIANT POWDERS

ALLIANT

BARREL: 4"

PRIMER: WINCHESTER SP

POWDER	STARTING LOADS			MAXIMUM LOADS		
	GRS.	VEL.	PRESSURE	GRS.	VEL.	PRESSURE
BULLET: 135 GR. JHP DIA. .400" C.O.L. 1.105"						
POWER PISTOL				9.3	1340	34,000 PSI
UNIQUE				8.5	1290	26,600 PSI
BULLSEYE				7.6	1350	33,600 PSI
BULLET: 150 GR. JHP DIA. .400" C.O.L. 1.105"						
BLUE DOT				11.5	1285	34,000 PSI
HERCO				8.2	1215	33,900 PSI
POWER PISTOL				8.2	1215	33,300 PSI
UNIQUE				8.0	1245	34,000 PSI
BULLSEYE				6.7	1225	34,000 PSI
BULLET: 170 GR. XTP DIA. .400" C.O.L. 1.124"						
BLUE DOT				9.8	1170	33,900 PSI
HERCO				7.4	1125	34,000 PSI
POWER PISTOL				7.3	1105	33,300 PSI
UNIQUE				6.7	1075	33,800 PSI
BULLSEYE				5.5	1015	33,500 PSI
BULLET: 180 GR. JHP DIA. .400" C.O.L. 1.125"						
BLUE DOT				8.8	1065	34,000 PSI
HERCO				7.0	1045	34,000 PSI
POWER PISTOL				6.9	1050	33,700 PSI
UNIQUE				6.4	1065	33,800 PSI
BULLSEYE				5.5	1015	33,900 PSI
BULLET: 190 GR. JHP DIA. .400" C.O.L. 1.130"						
BLUE DOT				8.7	1040	33,800 PSI
HERCO				6.7	1000	33,800 PSI
POWER PISTOL				6.9	1020	33,100 PSI
UNIQUE				6.1	1010	34,000 PSI
BULLSEYE				5.4	955	34,000 PSI
BULLET: 200 GR. FMJ DIA. .400" C.O.L. 1.130"						
BLUE DOT				7.9	960	33,800 PSI
HERCO				5.8	955	34,000 PSI
POWER PISTOL				6.3	960	33,700 PSI
UNIQUE				5.3	955	33,900 PSI
BULLSEYE				4.6	945	33,600 PSI

*See 40 S & W WARNING

.40 S&W - HODGDON POWDERS

40 S&W

The 40 S&W arrived with considerable fanfare in 1992. It is a short but very efficient case design that works best with bullet weights from 155 to 200 grains. This cartridge has an industry standard maximum of 35,000 PSI. Because this is a high intensity cartridge, the following warning should be observed.

**** 40 S&W WARNING:** *This data is intended for use in firearms which fully support the cartridge in the chamber. Use of this data in firearms which do not fully support the cartridge may result in bulged cases, ruptured cases, case head separation, or other conditions which may result in damage to the firearm and/or result in injury or death of the shooter and/or bystanders.*

• • •

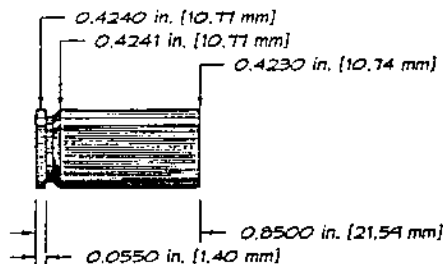

HORNADY
Branched 4

1-16
845

WINCHESTER SP

.40 S&W - HODGDON POWDERS

Powder	Starting Loads			Maximum Loads		
	Gr.	Vel.	Pressure	Gr.	Vel.	Pressure

.40 S&W

Case: HORNADY
Barrel: 4"

Trim: .845" Twist: 1:16"
Primer: WINCHESTER SP

Bullet: 135 GR. NOS JHP Dia.: .400" COL: 1.125"

HS-6	9.0	1180	27,400 PSI	10.2	1321	33,600 PSI
UNIVERSAL	6.8	1208	27,300 PSI	7.5	1324	32,500 PSI
HP-38	6.3	1152	29,900 PSI	7.0	1244	33,100 PSI
TITEGROUP	5.8	1155	27,300 PSI	6.4	1251	33,200 PSI
CLAYS	4.0	940	22,600 PSI	4.5	1071	32,900 PSI

Bullet: 155 GR. HDY XTP Dia.: .400" COL: 1.125"

HS-6	7.7	1035	26,500 PSI	8.5	1137	33,200 PSI
UNIVERSAL	6.0	1082	25,700 PSI	6.6	1186	33,300 PSI
HP-38	5.0	937	22,900 PSI	6.0	1103	33,000 PSI
TITEGROUP	5.4	1058	28,400 PSI	5.9	1139	31,700 PSI
CLAYS	3.6	854	23,300 PSI	4.0	942	30,900 PSI

Bullet: 170 GR. HDY XTP Dia.: .400" COL: 1.125"

HS-6	7.0	970	26,000 PSI	7.7	1078	33,200 PSI
UNIVERSAL	5.6	1008	27,700 PSI	6.3	1097	32,400 PSI
HP-38	4.4	847	23,900 PSI	5.3	1007	33,000 PSI
TITEGROUP	4.6	954	28,000 PSI	5.0	1025	32,000 PSI

Bullet: 180 GR. HDY XTP Dia.: .400" COL: 1.125"

HS-6	6.1	876	25,900 PSI	6.9	976	32,500 PSI
UNIVERSAL	5.0	973	26,500 PSI	5.8	1046	33,400 PSI
HP-38	4.1	797	23,800 PSI	5.0	947	32,900 PSI
TITEGROUP	4.2	877	26,500 PSI	4.7	978	33,300 PSI
CLAYS	3.0	727	26,000 PSI	3.5	847	34,300 PSI

Bullet: 200 GR. HDY XTP Dia.: .400" COL: 1.125"

HS-6	5.5	810	27,000 PSI	6.3	900	32,800 PSI
UNIVERSAL	4.0	824	25,000 PSI	4.7	903	33,600 PSI
HP-38	3.9	737	25,900 PSI	4.7	857	33,400 PSI
TITEGROUP	3.4	744	27,200 PSI	3.8	822	31,700 PSI

*40 S & W: This data is intended for use in firearms with barrels which fully support the cartridge in the chamber. Use of this data in firearms which do not fully support the cartridge may result in bulged cases, ruptured cases, case head separation, or other condition which may result in damage to the firearm and/or result in injury or death of the shooter and/or bystanders.

.40 S&W - IMR POWDERS

IMR						
CASE: WINCHESTER		BARREL: 4"		PRIMER: WINCHESTER SP		
POWDER	STARTING LOADS			MAXIMUM LOADS		
	GRS.	VEL.	PRESSURE	GRS.	VEL.	PRESSURE
BULLET: 180 GR. HDY XTP DIA: .400" C.O.L: 1.125"						
"HI-SKOR" 800-X				8.2	1160	34,700 PSI
SR 4756				6.0	1000	33,100 PSI
SR 7625				5.7	990	33,300 PSI
PB				5.1	975	34,400 PSI
"HI-SKOR" 700-X				4.6	970	34,600 PSI
BULLET: 200 GR. SPR TMJ DIA: .400" C.O.L: 1.125"						
"HI-SKOR" 800-X				7.0	1000	32,000 PSI
SR 4756				5.6	905	34,200 PSI
SR 7625				5.2	885	34,100 PSI
PB				4.5	845	33,900 PSI
"HI-SKOR" 700-X				4.3	840	33,800 PSI

NEVER EXCEED MAXIMUM LOADS.

40 S & W - WINCHESTER POWDERS

WINCHESTER

CASE: WINCHESTER

BARREL: 4"

PRIMER: WINCHESTER SP

BULLET: 150 GR. WIN JHP DIA: .400" C.O.L: 1.135"

WSF	6.7	1100	26,200 PSI	7.7	1200	33,200 PSI
231	5.2	970	21,800 PSI	6.3	1150	33,200 PSI
WST	5.5	990	23,900 PSI	6.3	1050	27,100 PSI

BULLET: 155 GR. WIN JHP DIA: .400" C.O.L: 1.135" MAX

WSF	6.0	1010	21,600 PSI	7.3	1180	33,200 PSI
231	5.1	950	23,200 PSI	6.0	1100	33,200 PSI
WST	5.5	980	24,000 PSI	6.0	1040	27,900 PSI

BULLET: 170 GR. WIN JHP DIA: .400" C.O.L: 1.135" MAX

WSF	5.5	920	23,300 PSI	6.5	1080	33,200 PSI
231	4.5	860	24,000 PSI	5.3	1000	33,200 PSI
WST	4.2	830	22,100 PSI	5.5	970	30,100 PSI

BULLET: 180 GR. WIN JHP DIA: .400" C.O.L: 1.135" MAX

WSF	5.0	860	22,900 PSI	6.2	1040	33,200 PSI
231	4.0	790	23,700 PSI	5.0	950	33,200 PSI
WST	4.0	780	21,800 PSI	5.0	900	28,100 PSI

BULLET: 200 GR. WIN FMJ DIA: .400" C.O.L: 1.135" MAX

WSF	4.9	840	25,600 PSI	5.7	930	33,200 PSI
231	4.0	750	26,600 PSI	4.7	850	33,200 PSI
WST	3.8	740	24,200 PSI	4.5	810	29,900 PSI

*See 40 S & W WARNING

NEVER EXCEED MAXIMUM LOADS.

40 S & W - VIHTAVUORI POWDERS

.40 S.&W.

CIP max. dimensions in millimetres (inches)

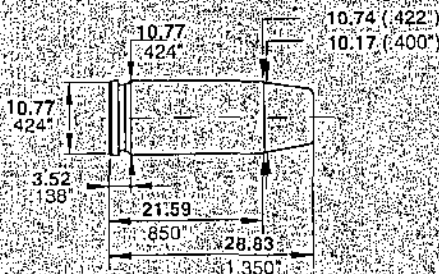

Country of origin:	USA
Year of introduction:	1990
Max. bullet diameter:	10.17 mm (.400")
Max. cartridge length:	28.83 mm (1.135")
Max. shell length:	21.59 mm (.850"), trim to 21.40 mm (.840")
Max. CIP piezo pressure:	250 MPa (36200 psi)

The .40 S.&W. was developed as a joint-venture between Winchester and Smith & Wesson and introduced in 1989. In the late '80s the FBI of U.S.A. was working with the 10mm Auto-project, developing a load to meet their criteria for bullet diameter, weight and velocity. It was evident that the FBI requirements could be achieved using a shorter case, which would positively affect in the accuracy as well as allow use of a smaller grip frame. As a result a new 9mm Luger-length cartridge case was developed and the .40 S.&W. was born.

The very first pistols offered by Smith & Wesson in the .40 S.&W. were modified from the existing one chambered in 9mm Luger, the S&W Model 4006. Many working with law enforcement in the U.S.A. felt from the very beginning that the .40 S.&W. will be the cartridge of the future and significant changes in law enforcement sidearms will occur, even the switch to the 9mm had just begun among the law enforcement and military people worldwide.

If the .40 S.&W. will replace the 9mm Luger, the 45 ACP, the 38 Special or the .357 Magnum as a service cartridge, only the time will tell. The IPSC people have found the cartridge an affordable one for the IPSC standard class, offering "major" with good accuracy combined with tolerable recoil. The firearms chambered in the .40 S.&W. are compact offering large magazine capacity, an important factor for a serious IPSC shooter.

40 S & W - VIHTAVUORI POWDERS

.40 S.&W.

TEST COMPONENTS:

Test barrel: 140 mm (5 1/2"), 1 in 16" twist, manufactured to meet CIP minimum dimensions.

Primers: Small Pistol

Cases: Remington, trim-to length 21.40 mm (.842")

Reloading Data, English Units:

Weight (grs)	Type	Mfg.	C.O.L. (in.)	Powder		Maximum Load			
				Type	Weight (grs)	Velocity (fps)	Weight (grs)	Velocity (fps)	Pressure (psi)
155	HP-XTP	Hornady	1.126	N320	5.2	1106	5.9	1191	max.
				N330	6.0	1142	6.7	1234	max.
				N340	6.0	1132	6.9	1250	max.
				3N37	7.3	1171	8.1	1286	max.
				N350	6.6	1152	7.6	1263	max.
155	FP	Raimier	1.126	N320	5.3	1086	5.9	1171	max.
				N330	6.0	1129	6.7	1224	max.
				N340	6.4	1155	7.3	1276	max.
				N350	7.2	1171	8.1	1296	max.
				3N37	7.5	1178	8.5	1293	max.
170	HP	Hornady	1.126	N340	5.3	1027	6.1	1135	max.
				3N37	6.0	1056	7.0	1165	max.
				N350	5.8	1056	6.8	1161	max.
180	HP	Speer	1.126	N340	5.5	1001	6.1	1109	max.
				3N37	5.8	994	6.8	1115	max.
				N350	5.9	1047	6.7	1142	max.
200	TMJ	Speer	1.126	N340	4.7	876	5.4	978	max.
				3N37	5.1	869	6.0	988	max.
				N350	5.3	892	6.0	991	max.
				N105	7.5	1053	8.0	1132	max.

INDICATES MAXIMUM LOAD - USE WITH CAUTION!
LOADS LESS THAN MINIMUM CHARGES SHOWN ARE NOT RECOMMENDED

.41 ACTION EXPRESS - HORNADY BULLETS

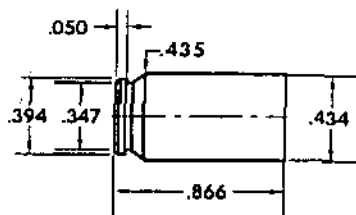

41 ACTION EXPRESS

HANDGUN: UZI
BARREL: .. 16", 1 in 18½" Twist
CASE: IMI
PRIMER: WSP

BULLET DIAMETER: 0.410"
MAXIMUM C.O.L.: 1.150"
MAX. CASE LENGTH: ... 0.866"
CASE TRIM LENGTH: ... 0.856"

Developed by Evan Whilden, vice president of Action Arms, the 41 Action Express was intended to improve the performance of the Uzi submachine gun. Initial experiments produced a variety of designs (one of which was nearly identical to the 40 S&W). The final configuration was based on 41 Magnum cases trimmed to .866" with the head altered to match that of the 9mm Luger case. The result was a short, squat 41 caliber cartridge with a rebated rim. It would allow any owner of an Uzi or other firearm to change from 9mm to 41 AE by simply switching barrels and magazines. Other parts of the firearm, such as the extractor need not be altered.

Several manufacturers offered pistols in 41 AE, including Taurus, F.I.E., Excam and K.B.I., and Action Arms offered conversion kits. Factory ammunition came from Action Arms and Samson.

Though the 41 AE is a fine cartridge, the introduction of the 10mm Auto and the 40 S&W and firearms for these cartridges from most large American manufacturers quickly eroded interest in the Action Express. Few bullets are available in 41 caliber, compared to 10mm, so even handloading the 41 AE doesn't offer a bright future.

A 16" barrel produced our data, and velocities in a 5" pistol barrel would probably average 100 to 150 fps lower than those listed.

.41 ACTION EXPRESS - SIERRA BULLETS

41 Action Express

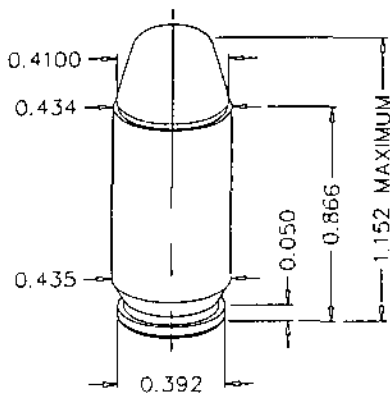

Test Specifications/ Components

Firearm Used: Colt Gov't Model
(conversion)

Barrel Length: 5"

Twist: 1 x 16"

Case: Samson (IMI)

Trim-to Length: 0.861"

Primer: Federal 100

Remarks:

The 41 Action Express started out as a fine idea that has been overtaken by other events. Originally conceived as a way to provide greatly improved performance in 9mm handguns, the 41 AE utilized a novel approach to attain this increase. Designed by Evan

Whildin, then Executive Vice President of Action Arms, the 41 AE uses a rebated case with the same head dimensions as the standard 9mm Luger. The case body, however, is dimensioned to accept .410" diameter bullets. This allows virtually any 9mm handgun to be rebarreled to the 41 AE, while requiring no alteration to either the slide or extractor. In most instances, the only components necessary are a new barrel, magazine, and in some cases, a heavier recoil spring.

Our test firearm was a Colt Government Model conversion with a Bar-Sto barrel and a Delta Elite 10mm magazine. The test firearm, originally a 9mm Luger, demonstrates the versatility of the 41 AE cartridge. At the completion of testing, the gun was returned to its 9mm configuration simply by changing magazines and replacing the original factory 9mm barrel. Action Arms still offers conversion kits for the Browning High Power, providing a simple and cost effective way to upgrade the performance of this classic 9mm pistol.

Loading for the 41 AE presents no special challenges. Component availability is probably the greatest concern, as 41 AE cases cannot be easily reformed from any existing case. Bullets in this caliber were originally designed for the 41 Magnum, but gave good results in our test pistol. While these bullets do have a cannelure, it must be disregarded for crimping purposes. Like other cartridges that headspace on the case mouth, the 41 AE should only be taper crimped enough to remove any remaining flaring of the case mouth. Although the 41 AE gave excellent results, the development of the 40 S&W has cast a dark cloud over its future.

.41 ACTION EXPRESS - SIERRA BULLETS

41 Action Express *continued*

#8500 .410" 170 grain JHC
C.O.A.L. 1.150"



Powder/Velocity--	850	900	950	1000	1050	1100	1150
231	4.5	4.9	5.3	5.7			
452AA	4.0	4.5	5.0				
Unique	5.4	5.7	6.0	6.3	6.6	6.9	7.2
473AA	5.1	5.6	6.1	6.6	7.1	7.6	
HS-6	6.6	7.0	7.4	7.8	8.2	8.6	
Herco	5.1	5.5	5.9	6.3	6.7	7.1	7.5
800X	5.5	6.0	6.5	7.0	7.5	8.0	8.5
AA-No. 7	8.0	8.5	9.0	9.5	10.0	10.5	11.0
Blue Dot	6.8	7.3	7.8	8.4	9.0	9.5	
Energy/ft.lbs.	273	306	341	377	416	457	499

	Powder	Grains	Velocity	Ft. lbs.
Accuracy Load	Unique	6.9	1100	457
Hunting Load	AA-No. 7	11.0	1150	499

#8520 .410" 210 grain JHC
C.O.A.L. 1.150"



Powder/Velocity--	700	750	800	850	900	950
231	3.9	4.2	4.5	4.8		
452AA	3.7	4.2	4.7	5.2		
Unique	4.2	4.5	4.8	5.2	5.5	
473AA	4.3	4.8	5.3	5.8		
HS-6	5.7	6.0	6.2	6.5	6.7	
Herco	4.5	4.8	5.1	5.4	5.7	6.1
800X	4.7	5.1	5.5	5.9	6.4	6.9
AA-No. 7	6.6	7.1	7.6	8.1	8.6	9.1
Blue Dot	5.8	6.2	6.6	7.0	7.4	7.8
Energy/ft.lbs.	228	262	298	337	378	421

	Powder	Grains	Velocity	Ft. lbs.
Accuracy Load	Herco	5.7	900	373
Hunting Load	AA-No. 7	9.1	950	421

INDICATES MAXIMUM LOAD - USE CAUTION
LOADS LESS THAN MINIMUM CHARGES SHOWN ARE NOT RECOMMENDED.

.41 ACTION EXPRESS - SPEER BULLETS

The 41 Action Express is another interesting cartridge from the fertile mind of Evan Whildin (see the section on the 50 Action Express). While working at Action Arms, Ltd., Whildin sought a way to obtain performance similar to that of the 45 Auto in a cartridge that would function in smaller pistols designed for the 9mm Luger cartridge. He also had in mind a system to allow shooters to switch to a different cartridge in one pistol by simply changing the barrel, magazine and, in some cases, the recoil spring. Firearms consultant Robert Olsen also had a hand in the research. The resulting 41 Action Express was announced in 1987, three years before the 40 S&W cartridge appeared.

This goal was accomplished in prototype form by shortening a 41 Magnum case and rebating the rim to 9mm Luger dimensions. This allowed conversion of 9mm pistols because the rebated rim fit their breech face. The overall length of the loaded round was established to match the 9mm cartridge. Originally, 170 grain JHP 41 Magnum bullets were used, but exposed lead at the nose caused feeding problems in some semi-autos. Later, Action Arms imported Israeli-made Samson ammunition with a 200 grain FMJ bullet at about 950 feet/second in production pistols. Action Arms developed a pistol for this cartridge and also marketed conversion units for Colt and Browning pistols as well as their own AT-84 9mm pistol. Several other variants of the CZ-75 design such as the Kassnar Jericho have also been available in 41 AE. Although an excellent cartridge, the 41 AE has been dropped by many pistol makers in favor of the newer 40 S&W.

The 41 AE was initially handicapped by a limited supply of loaded ammunition and a lack of bullets suitable for semi-auto pistols. The only bullets in this diameter (0.410") were intended for revolvers.

Blount engineers worked with Israeli Military Industries (IMI) to develop Speer Gold Dot 41 AE ammunition. Our factory ammunition fires a 180 grain Gold Dot hollow point bullet at a nominal velocity of 1000 feet/sec. This matches the performance of the 40 Smith & Wesson almost exactly. Speer also offers the same bullet as a reloading component.

Loading of the 41 AE is no different than other similar cartridges. Propellants which perform well in the 40 S&W also do well in the 41 AE. The loads listed do not exceed the SAAMI pressure limit of 35,000 psi.

.41 ACTION EXPRESS - SPEER BULLETS

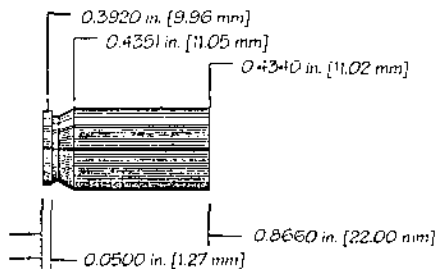

Max. Case Length: 0.860"
 Trim-to Length: 0.850"
 Max. Cart. Length: 1.152"
 RCBS Shellholder: #16
 Barrel Length: 4.375"

Test Firearm: Jericho Model 941
 Case: Speer
 Primers: CCI 500



.410" Dia.
180 Grain

Sect. Density .153

	41AE					
	HP					
Ballistic Coefficient	0.138					
C.O.L. Tested At	1.100"					
Speer Part No.	4404					

Powder	Wt. Grs.	Mzl.Vel.	Powder	Wt. Grs.	Mzl.Vel.	Powder	Wt. Grs.	Mzl.Vel.
Blue Dot	9.1	1092	HS-7	9.5	1032	AA #5	7.8	1015
	8.2	1012		8.6	950		7.1	918
	7.4	1079		8.2	1029		SR 7625	6.0
Herco	6.7	984	HS-6	7.4	955	AA #2	5.4	958
	5.5	1069		5.4	1026		5.9	997
700-X	5.5	1008	Bullseye	4.9	957	WSL	5.4	951
	8.3	1052		5.8	1024		5.1	993
540	7.5	937	PB	5.3	968	HP-38	4.6	910
	7.0	1045		6.4	1019		5.6	991
Unique	6.4	1000	WSF	5.8	982		5.1	922

Notes: Bold print denotes maximum loads. They should be used with caution.

.41 ACTION EXPRESS - HODGDON POWDERS

41 ACTION EXPRESS

The 41 AE was an innovative design that allowed police departments and other law enforcement agencies to upgrade their 9mm service pistols to 41 by simply switching barrels. The case was a rebated design with a body similar to the 40 S&W with a rim diameter of the 9mm making it possible to swap barrels and still use the same basic action for both 9mm and 41. The concept made good sense, until the 40 S&W showed up and spoiled the plan. Still, the 41 AE is just about ideal for law enforcement, as is the 40 S&W.

• • •

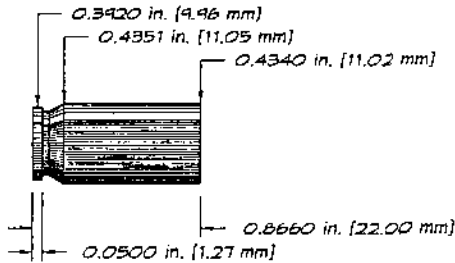

SPEER
5"

CCI 500

1:16"
861"

10MM MAGNUM - ACCURATE POWDERS

10mm MAGNUM

This proprietary cartridge was developed for Irwindale Arms, Inc. for use in their auto loading pistol.

The 10mm Magnum could be thought of as a rimless .401 Power Mag, if anyone should happen to remember Herter's proprietary revolver and cartridge. Both cartridges approximate the .41 Magnum in power.

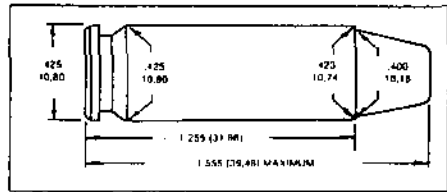

This cartridge is a lengthened 10mm Auto and is loaded to pressure levels similar to the .44 Magnum for use in the IAI handguns.

10mm MAGNUM			
Gun	IAI	Max Length	1.255"
Barrel Length	8"	Trim Length	1.245"
Primer	CCI 300	OAL Max	1.555"
Case	STARLINE	OAL Min	1.500"

Bullet	START LOADS			MAXIMUM LOADS			C.U.P.	Cartridge Length	Comment
	Powder	Grains	Vel.	Powder	Grains	Vel.			
165 (L) SWC	No.7	13.0	1305	No.7	14.4	1483	31,400	1.520"	Clements
	No.9	15.1	1356	No.9	16.8	1541	30,700		
175 (L) SWC	No.7	12.4	1266	No.7	13.8	1439	32,100	1.520"	CP
	No.9	14.1	1285	No.9	15.7	1460	31,600		
185 (L) FPBB	No.7	11.9	1213	No.7	13.2	1378	31,400	1.520"	Co. Custom
	No.9	13.5	1231	No.9	15.0	1399	30,000		
195 (L) FN	No.7	11.5	1199	No.7	12.8	1363	31,500	1.500"	Clements
	No.9	12.9	1193	No.9	14.3	1356	30,300		
NOS 135 JHP	No.7	15.0	1494	No.7	16.7	1698	37,200	1.550"	
	No.9	17.8	1551	No.9	19.8	1763	36,800		
NOS 150 JHP	No.7	14.2	1358	No.7	15.8	1543	37,300	1.550"	
	No.9	16.7	1443	No.9	18.6	1640	36,300		
HDY 155 JHP	No.7	14.0	1371	No.7	15.5	1558	36,000	1.555"	
	No.9	16.2	1385	No.9	18.0	1574	36,700		
NOS 170 JHP	No.7	13.1	1271	No.7	14.5	1444	36,100	1.555"	
	No.9	15.3	1324	No.9	17.0	1505	35,800		

10MM MAGNUM - ACCURATE POWDERS

Bullet	START LOADS			MAXIMUM LOADS			C.U.P.	Cartridge Length	Comments
	Powder	Grains	Vel.	Powder	Grains	Vel.			
SPR 180 JHP	No.7	13.2	1243	No.7	14.7	1412	37,600	1.550"	
	No.9	14.9	1280	No.9	16.6	1455	38,500		
SRA 190 FPJ	No.7	12.8	1206	No.7	14.2	1370	39,000	1.550"	
	No.9	14.7	1265	No.9	16.3	1438	36,100		
SPR 200 TMJ	No.7	12.4	1144	No.7	13.8	1300	37,600	1.550"	
	No.9	14.1	1222	No.9	15.7	1369	35,200		

LOAD FOR IAI GUNS ONLY

NOS 135 JHP	No.9	20.3	1672	No.9	22.5	1900	42,100	1.550"	
NOS 150 JHP	No.9	18.9	1558	No.9	21.0	1770	42,600	1.550"	
HDY 155 JHP	No.9	18.2	1507	No.9	20.2	1712	40,000	1.555"	
NOS 170 JHP	No.9	17.3	1421	No.9	19.2	1615	43,200	1.555"	
SPR 180 JHP	No.9	15.8	1323	No.9	17.5	1503	42,000	1.555"	
SRA 190 FPJ	No.9	15.8	1291	No.9	17.5	1467	40,500	1.550"	
SPR 200 TMJ	No.9	15.3	1260	No.9	17.0	1432	41,500	1.550"	

POWDER BURNING RATE CHART

Current Canister Grade Powders in order of approximate burning rate.
 (R1 being the fastest, 748 the slowest)
 This list is approximate only and not to be used for developing loads.

1. R-1, Norma	36. No. 9, Accurate Arms
2. N31, Vihtavuori	37. R123, Norma
3. TITEWAD, Accurate Arms	38. N110, Vihtavuori
4. RED DOT, Alliant	39. H110 Hodgdon
5. CLAYS, Hodgdon	40. 296, Winchester
6. "HI-SKOR" 700-X, IMR Co.	41. IMR4227, IMR Co.
7. BULLSEYE, Alliant	42. H4227, Hodgdon
8. TITEGROUP, Hodgdon	43. SR4759, IMR Co.
9. American Select, Alliant	44. 1680, Accurate Arms
10. SOLO 1000, Accurate Arms	45. 200, Norma
11. GREEN DOT, Alliant	46. Reloader 7, Alliant
12. INTERNATIONAL, Hodgdon	47. IMR4198, IMR Co.
13. PB, IMR Co.	48. H4198, Hodgdon
14. N320, Vihtavuori	49. N120, Vihtavuori
15. WST, Winchester	50. H322, Hodgdon
16. No.2, Accurate Arms	51. 2015 BR, Accurate Arms
17. SR 7625, IMR Co.	52. N130, Vihtavuori
18. HP-38, Hodgdon	53. IMR3031, IMR Co.
19. 231, Winchester	54. N133, Vihtavuori
20. UNIQUE, Alliant	55. H335, Hodgdon
21. UNIVERSAL, Hodgdon	56. N135, Vihtavuori
22. Power Pistol, Alliant	57. 2230, Accurate Arms
23. N330, Vihtavuori	58. 2460, Accurate Arms
24. HERCO, Alliant	59. H4895, Hodgdon
25. WSP, Winchester	60. IMR4895, IMR Co.
26. N340, Vihtavuori	61. RELOADER-12, Alliant
27. "HI-SKOR" 800-X, IMR Co.	62. IMR-4320, IMR Co.
28. SR4756, IMR Co.	63. 3100, Accurate Arms
29. NO. 5, Accurate Arms	64. IMR 4064, IMR Co.
30. HS-6, Hodgdon	65. 202, Norma
31. 3N37, Vihtavuori	66. 2520, Accurate Arms
32. N350, Vihtavuori	67. RELOADER-15, Alliant
33. BLUE DOT, Alliant	68. N140, Vihtavuori
34. No. 7, Accurate Arms	69. VARGET, Hodgdon
35. 2400, Alliant	70. 748, Winchester

This is a unique reloading/information manual. It contains currently available data regarding loading information for this individual cartridge. This data is compiled from the leading U.S. Bullet and gunpowder manufacturers.

This manual is not intended to replace the many comprehensive, in-depth reloading manuals available from a host of publishers, but instead provide you with a quick and *easy-to-use reference source* which will enable you to compare loads, types of powders, bullets and shot charges for components you may have on hand.

Loadbooks USA, Inc., also offers the following cartridges in this series of unique One Book/One Caliber reloading manuals: .22 Hornet, .220 Swift, .222 Remington, .223 Remington, .22-250 Remington, .225 Winchester, .243 Winchester, .244/6mm Remington, 6.5x55 Swedish, .25-06 Remington, .250-3000 Savage, .270 Winchester, 7x57 Mauser, 7mm-08 Remington, .280 Remington, .284 Winchester, 7mm Remington Magnum, 7.62x39mm, 7.62x54mm Russian, .30-30 Winchester, .303 British, .308 Winchester, .30-06 Springfield, .300 Winchester Magnum, .300 Weatherby Magnum, .300 Savage, 30/40 Krag, .300 & .375 H & H Magnum, .338 Winchester Magnum, 8mm Remington Magnum, 8mm/06 & .338/06, 8mm Mauser, .356 & .358 Winchester, .35 Whelen, .35 Remington & .350 Remington Magnum, .375 & .458 Winchester, .444 Marlin, .45-70 Government, .25 & .32 A.C.P., .32 H&R Magnum, .380 ACP, 9mm Luger, .38 Super, .38 Special, .357 Magnum, 10mm/.41 Auto, .41 Magnum, .44 Magnum, .44 Special, .45 ACP, .45 Colt, .454 Casull, and The Weatherby Magnums covering 10 different Weatherby calibers.

There's also two shotshell books for the 12 Gauge, and the 20/28 Gauge and .410 bore. Plus there's a large reloading manual covering 30 calibers for the Thompson/Center Contender single-shot pistol and the Remington XP-100 pistol.

Online Ordering <http://www.loadbooks.com>

Published by Loadbooks USA, Inc.

Printed in the United States