

The Complete Reloading Manual for the .38 Special

The publisher is deeply indebted to the following companies for their permission to reprint their proprietary reloading information found in this manual.

**Accurate Arms Company, Inc.
Blount, Inc.
Alliant Technologies
Hodgdon Powder Co., Inc.
Hornady Manufacturing Company
IMR Powder Company
Lyman Products Corporation
Nosler Bullets, Inc.
RCBS Bullets
Scot Powders
Sierra Bullets, L.P.
Speer Bullets
Winchester**

TABLE OF CONTENTS

.38 SPECIAL

HORNADY BULLETS

| | |
|-------------------------------|---|
| Hornady Introduction | 1 |
| Hornady 110 grain..... | 2 |
| Hornady 125 grain..... | 3 |
| Hornady 140 grain..... | 4 |
| Hornady 158 grain..... | 5 |
| Hornady 140 grain (lead)..... | 6 |
| Hornady 148 grain (lead)..... | 7 |
| Hornady 158 grain (lead)..... | 8 |

NOSLER BULLETS

| | |
|--------------------------|----|
| Nosler Introduction..... | 9 |
| Nosler 125 grain..... | 11 |
| Nosler 150 grain..... | 12 |
| Nosler 158 grain..... | 13 |

SIERRA BULLETS

| | |
|---------------------------|----|
| Sierra Introduction..... | 14 |
| Sierra 110/125 grain..... | 15 |
| Sierra 140 grain..... | 16 |
| Sierra 158 grain..... | 17 |
| Sierra 170/180 grain..... | 18 |

SPEER BULLETS

| | |
|----------------------------------|----|
| Speer Introduction..... | 19 |
| Speer 147 grain (Cowboy)..... | 20 |
| Speer 148/158 grain (lead)..... | 21 |
| Speer 110 grain..... | 22 |
| Speer 125 grain..... | 23 |
| Speer +P Loads Introduction..... | 24 |
| Speer 158 (Lead) +P Loads..... | 25 |
| Speer 110/125 +P Loads..... | 26 |
| Speer 140/146 +P Loads..... | 27 |

LYMAN BULLETS

| | |
|--------------------------|----|
| Lyman Introduction..... | 28 |
| Lyman 92 grain..... | 31 |
| Lyman 121/141 grain..... | 32 |
| Lyman 146/148 grain..... | 33 |
| Lyman 148 grain..... | 34 |
| Lyman 155 grain..... | 35 |
| Lyman 158 grain..... | 36 |
| Lyman 162/168 grain..... | 37 |

TABLE OF CONTENTS

.38 SPECIAL

RCBS BULLETS

| | |
|-----------------------------|----|
| RCBS 140/148/150 grain..... | 38 |
| RCBS 158/159/175 grain..... | 39 |

HODGDON POWDERS

| | |
|---------------------------|----|
| Hodgdon Introduction..... | 40 |
| Standard Loads..... | 41 |
| +P Loads..... | 43 |

ACCURATE ARMS POWDERS

| | |
|----------------------------|----|
| Accurate Introduction..... | 45 |
| Standard Loads..... | 46 |
| +P Loads..... | 48 |

HERCULES POWDERS

| | |
|---------------------|----|
| Standard Loads..... | 49 |
| +P Loads..... | 51 |

IMR POWDERS

| | |
|---------------------|----|
| Standard Loads..... | 52 |
| +P Loads..... | 54 |

SCOT POWDERS

| | |
|--------------------------------------|----|
| Royal Scot/Pearl Scot/Solo 1000..... | 55 |
| Solo 1250/Solo 1500..... | 56 |

WINCHESTER POWDERS

| | |
|---------------------|----|
| Standard Loads..... | 57 |
| +P Loads..... | 58 |

VIHTAVUORI POWDERS

| | |
|------------------------------|----|
| Vihtavuori Introduction..... | 59 |
| 110-125 grain Loads..... | 60 |
| 140-160 grain Loads..... | 61 |

The Hornady Handbook of Cartridge Reloading 5th Ed.

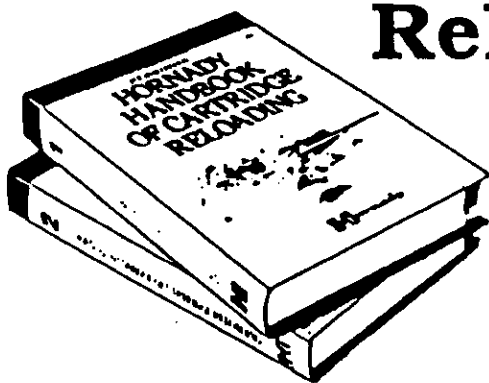

This new two-volume set contains the most up-to-date reloading information available. Volume I contains the loading formulas for all Hornady rifle and pistol bullets. Volume II contains the ballistic tables and charts you need to fine tune your loads.

This two-volume format enables you to have both the loading formulas and ballistics tables open to the same caliber without having to thumb back and forth.

Available at your reloading dealer.

 **ornady**

OUR REPUTATION RIDES ON EVERY SHOT

Hornady Mfg. Co., Box 1848, Grand Island, NE 68802-1848

*Save time on your
next shot!*



Hornady ONE SHOT Gun Cleaner and Case Lube.

In the field or on the loading bench
Fast drying, non-oily
Cleans and lubes bullets, presses and guns

 **Hornady**

OUR REPUTATION RIDES ON EVERY SHOT

Hornady Mfg. Co., Box 1848, Grand Island, NE 68802-1848

.38 SPECIAL - HORNADY BULLETS

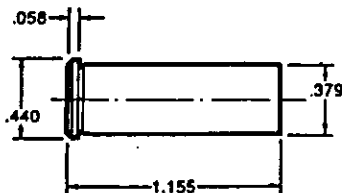

38 SPECIAL

HANDGUN: S & W Model 15
BARREL: . . . 4", 1 in 18 $\frac{1}{4}$ " Twist
CASE: Hornady/Frontier
PRIMER: Winchester WSP

BULLET DIAMETER: 0.357"
MAXIMUM C.O.L.: 1.550"
MAX. CASE LENGTH: . . . 1.155"
CASE TRIM LENGTH: . . . 1.145"

Smith & Wesson introduced the 38 Special in 1902 in their Military and Police Model revolver. Since that time, the 38 Special has become one of the world's most reloaded centerfire cartridges. It is a very popular sidearm, used by law enforcement agencies throughout the U. S. Because of its popularity the 38 is chambered in nearly all revolvers, and in the Thompson/Center Contender as well.

The versatility of the 38 Special is to the handgunner what the 308 Winchester is to the rifleman. The 38 Special can be used for everything from self-defense to plinking to small game hunting to target shooting, with excellent results.

To realize the full potential of the 38 Special, Hornady offers 10 bullet choices, 4 lead bullets and 6 jacketed bullets. The 148 HBWC is the most accurate target bullet. Wadcutters are not suitable for high velocity loads. For best results in target shooting, loads at 800 fps give optimum performance. Maximum loads listed with an asterisk yield +P pressures. +P pressures are above the SAAMI standard for the 38 Special and should only be used in modern guns designed by the manufacturer for +P pressures. Some powders do not show +P loads because the next increment would yield higher than +P pressures. Our test weapon produced its best groups using Bullseye and Unique, with the highest velocities obtained from HS-6.

.38 SPECIAL - HORNADY BULLETS

110 GRAIN BULLETS

SECTIONAL DENSITY: 0.123
DIAMETER: 0.357"



#35700 HP-XTP
B.C.: 0.131 C.O.L.: 1.445"

| POWDER | VELOCITY (FPS—feet per second) | | | | | |
|------------|--------------------------------|---------|---------|----------|----------|----------|
| | 850 | 900 | 950 | 1000 | 1050 | 1100 |
| 700 X | 4.1 gr. | 4.4 gr. | 4.7 gr. | 5.0 gr. | *5.3 gr. | *5.5 gr. |
| TITEGROUP | 4.0 gr. | 4.4 gr. | 4.7 gr. | 5.0 gr. | *5.4 gr. | |
| Bullseye | 4.2 gr. | 4.5 gr. | 4.9 gr. | 5.2 gr. | *5.6 gr. | *6.0 gr. |
| VIHT N-320 | 4.5 gr. | 4.8 gr. | 5.0 gr. | 5.2 gr. | | |
| WIN 231 | 4.6 gr. | 5.0 gr. | 5.3 gr. | 5.6 gr. | 5.9 gr. | *6.3 gr. |
| AA No. 2 | 4.7 gr. | 5.1 gr. | 5.4 gr. | *5.7 gr. | | |
| Unique | 5.2 gr. | 5.5 gr. | 5.7 gr. | 6.0 gr. | *6.3 gr. | |
| VIHT N-340 | 5.5 gr. | 5.9 gr. | 6.2 gr. | *6.6 gr. | | |
| POWER PIST | 5.6 gr. | 6.0 gr. | 6.4 gr. | 6.7 gr. | 7.1 gr. | *7.5 gr. |
| HS-6 | 6.8 gr. | 7.2 gr. | 7.6 gr. | 8.0 gr. | *8.4 gr. | |
| AA No. 5 | 6.9 gr. | 7.3 gr. | 7.7 gr. | *8.0 gr. | *8.4 gr. | |

***** indicates maximum load • use with caution

.38 SPECIAL - HORNADY BULLETS

158 GRAIN BULLETS

SECTIONAL DENSITY: 0.176
DIAMETER: 0.358"



#10408 SWC
B.C.: 0.135 C.O.L.: 1.455"



#10508 LRN
B.C.: 0.159 C.O.L.: 1.455"



#10428 SWC-HP
B.C.: 0.139 C.O.L.: 1.455"

| POWDER | VELOCITY (FPS—feet per second) | | | | | |
|-------------|--------------------------------|---------|---------|---------|---------|---------|
| | 650 | 700 | 750 | 800 | 850 | 900 |
| 700 X | 2.7 gr. | 3.0 gr. | 3.3 gr. | 3.7 gr. | | |
| Bullseye | 2.8 gr. | 3.1 gr. | 3.4 gr. | 3.7 gr. | | |
| NITRO 100 | 2.8 gr. | 3.1 gr. | 3.4 gr. | 3.7 gr. | | |
| AMER SELECT | 2.8 gr. | 3.2 gr. | 3.5 gr. | 3.9 gr. | | |
| WIN 231 | 3.2 gr. | 3.5 gr. | 3.8 gr. | 4.1 gr. | 4.4 gr. | |
| AA No. 2 | 3.3 gr. | 3.6 gr. | 3.8 gr. | | | |
| Unique | 3.3 gr. | 3.6 gr. | 3.9 gr. | 4.2 gr. | | |
| CLAYS UNIV | 3.4 gr. | 3.7 gr. | 3.9 gr. | 4.2 gr. | 4.4 gr. | |
| VIHT N-340 | 3.6 gr. | 3.9 gr. | 4.2 gr. | 4.5 gr. | | |
| POWER PIST | 4.0 gr. | 4.3 gr. | 4.6 gr. | 4.9 gr. | 5.2 gr. | |
| HS-8 | 4.7 gr. | 5.0 gr. | 5.3 gr. | 5.6 gr. | 5.9 gr. | 6.3 gr. |

■ indicates maximum load • use with caution

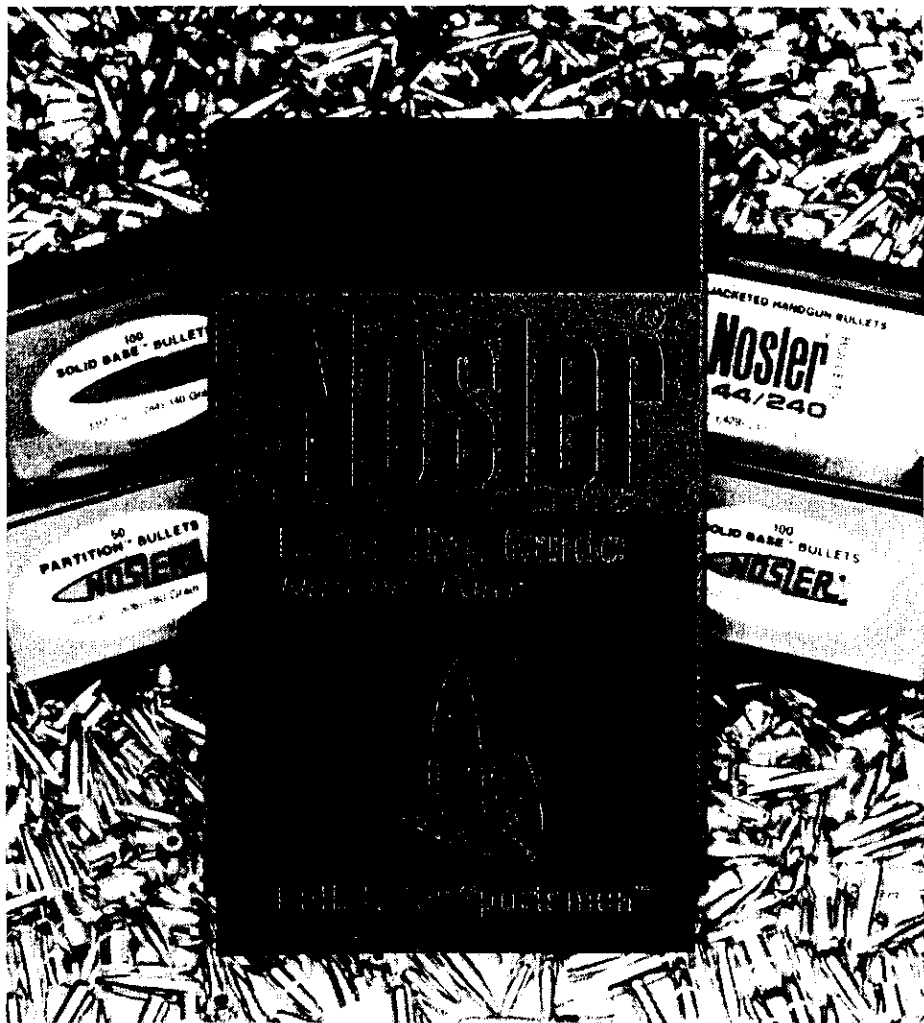

The One You've Been Waiting For

Nosler's *Reloading Manual Number Four* is the most complete volume on reloading ever. A full 722 pages with never-before-published data on Nosler Ballistic Tip and Handgun bullets, and new data on Solid Base® and Partition® bullets.

- Feature articles by Bob Milek and Layne Simpson with a special foreword by Rick Jamison.
- Advice, anecdotes, personal experiences on over 70 cartridges by the industry's top writers including *Guns Magazine's* own Col. Charles Askins, Jon Sundra, Charles Petty and Ed Matunas, as well as Bill Jordan, Hal Swiggett, Jim Carmichel and many others.
- How-to sections on reloading rifle and handgun cartridges, reloading with progressive tools, evaluating handgun hunting loads and more.
- Deluxe gold-embossed leather-grain cover.

Available now at your favorite gun dealer.

NOSLER
Nosler[®] BULLETS

P.O. Box 671, Bend, Oregon 97709
 (503) 382-3921

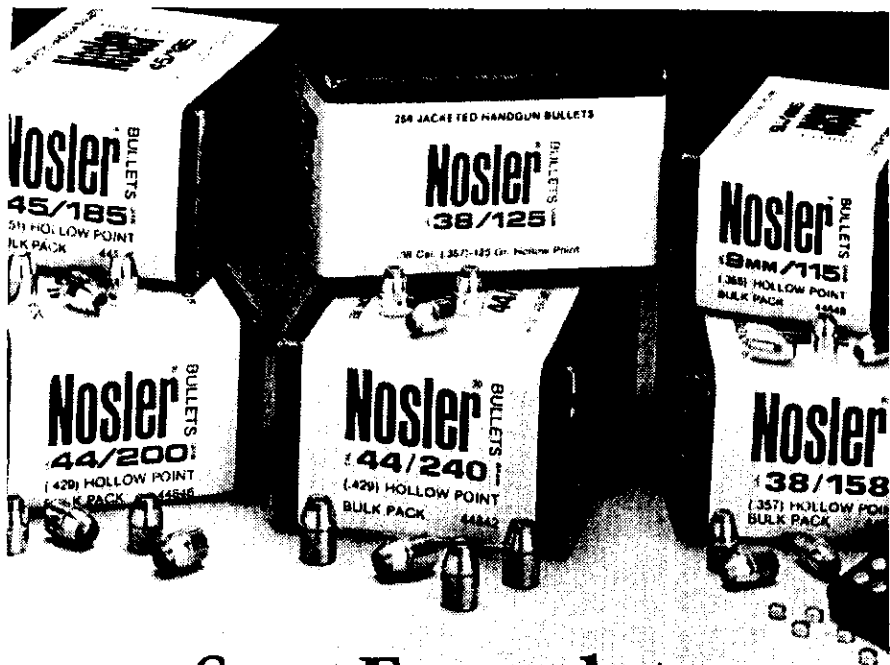

Save Enough to Pay for the Primers

Buy Nosler Handgun Bullets in 250 quantity Bulk Packs and save over 15% off the cost of buying the same bullets in our already low-priced 100-count boxes — enough extra savings for about 250 primers.

Add to the savings the kind of superb accuracy, consistency and expansion that you can really count on and you'll see why Nosler is your best choice for handgun hunting, target shooting or just plain plinking.

Nosler Handgun Bullet Bulk Packs are available in many popular calibers and weights and can be found at your

favorite gun shop or sporting goods store. And while you're there, pick up a copy of the new *Nosler Reloading Manual Number Four*. A full 722 pages, the manual contains never-before-published data on Nosler Handgun bullets as well as new data for Partition®, Solid Base and Ballistic Tip rifle bullets.

For a free catalog, write:
Nosler Bullets, Inc.
Dept. LB-1
P.O. Box 671
Bend, Oregon 97709

Nosler[®] BULLETS
Handgun

.38 SPECIAL - NOSLER BULLETS

I fired my first centerfire handgun at the age of 11. It was a Colt Single Action Army that had been converted to .38 Special sometime after World War II. The old Colt shot quite well, and I vowed someday to own just such a handgun.

Of course, the day finally came, and I found a Colt Single Action Army .38 Special in a pawn shop and promptly snapped it up. Except for very short periods, I haven't been without a .38 Special since.

The remarkable fact about the .38 Special is that it doesn't much matter what kind of sixgun it is chambered in, from light-weight snub nose revolvers to long barreled target rigs, it shoots well—well enough to be considered the all-time great target cartridge by the masters of the game.

Not being a target shooter or a plinker, the .38 Special earned its spurs riding with me across the high deserts of Oregon, Nevada and Utah in pursuit of small game, coyotes and badgers. In time, I came to prefer the 125-grain jacketed hollow points at around 1,000 fps from the 4.75-inch barreled Colt and a Smith & Wesson Model 19 with a four-inch tube. Accuracy with either sixgun was excellent, and I earned enough in the winter pelt market to pay for all my bullets and reloading supplies several times over.

Looking back over the long history of the .38 Special, it's almost remarkable that it has held its own against the influx of high capacity 9mm, 10mm and .45 ACP semiautomatics. Then too, considering its accuracy potential with just about any bullet and powder charge you care to stuff in the case, it is no mystery that it has remained at the top of the popularity charts with reloaders and shooters for nine decades. Like a law enforcement officer acquaintance opined, "If you can't get the job done with five or six shots from a .38 Special, there's a slim chance you will get it done with 10 or 15 shots from anything else." I couldn't agree more.



Dave Jell

Dave is Editor of Handloader, Hunting Horizons and Rifle magazines.

.38 SPECIAL - NOSLER BULLETS

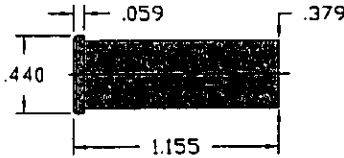

| | |
|----------------|-----------------------|
| RIFLE: | Barrel: H&S Precision |
| | Length: 7.75" |
| | Twist: 1-16" |
| CASE: | Federal |
| PRIMER: | Win. WSP |

Comments from the lab

Loading the .38 Special with slower burning powders like AA-No. 5 will produce the best results in barrels four inches or longer. In short barreled revolvers, faster burning powders like AA-No. 2 or Superlite (WSL) are more efficient.

When loading for the .38 Special, as with any revolver cartridge, seat the bullet so that the top of the cannelure is just visible above the case mouth and then give it a good roll crimp. The crimp should be such that you can just see that the case mouth is beginning to deform the ridges in the cannelure.

.38 SPECIAL - NOSLER BULLETS

Nosler
125 Grain



125 gr.
Hollow Point

*Most Accurate Load Tested

**Compressed Load

Ballistic Coefficient .143

Sectional Density .140

| Powder | Charge Weight in Grains | Muzzle Velocity (fps) | Load Density |
|--|-------------------------|-----------------------|--------------|
| WST | Max. 4.4 | 940 fps | 25% |
| | 3.9 | 860 fps | 22% |
| | 3.4* | 780 fps | 19% |
| WSL | Max. 4.8 | 988 fps | 27% |
| | 4.3 | 883 fps | 24% |
| | 3.8* | 778 fps | 22% |
| AA-No. 2 | Max. 4.6 | 900 fps | 26% |
| | 4.1 | 760 fps | 23% |
| | 3.6* | 620 fps | 20% |
| W 231 | Max. 5.7* | 1060 fps | 32% |
| | 5.2 | 970 fps | 30% |
| | 4.7 | 880 fps | 27% |
| HERCO | Max. 5.9* | 1030 fps | 34% |
| | 5.4 | 920 fps | 31% |
| | 4.9 | 810 fps | 28% |
| AA-No. 5 (Most Accurate Powder Tested) | Max. 7.2* | 998 fps | 41% |
| | 6.7 | 903 fps | 38% |
| | 6.2 | 808 fps | 35% |
| IMR 4227 | Max. 11.4* | 960 fps | 65% |
| | 10.9 | 900 fps | 62% |
| | 10.4 | 840 fps | 59% |

Use Maximum Loads with Caution

.38 SPECIAL - NOSLER BULLETS

Nosler

150 Grain



150 gr.
Soft Point

*Most Accurate Load Tested
**Compressed Load

Ballistic Coefficient .153
Sectional Density .168

| Powder | Charge Weight in Grains | Muzzle Velocity (fps) | Load Density |
|--|-------------------------|-----------------------|--------------|
| 700 X | Max. 3.6 | 802 fps | 23% |
| | 3.1 | 697 fps | 20% |
| | 2.6* | 592 fps | 17% |
| WSL | Max. 4.0 | 810 fps | 26% |
| | 3.5 | 690 fps | 22% |
| | 3.0* | 570 fps | 19% |
| W 231 | Max. 4.8* | 878 fps | 31% |
| | 4.3 | 783 fps | 27% |
| | 3.8 | 688 fps | 24% |
| UNIQUE | Max. 5.1* | 880 fps | 33% |
| | 4.6 | 730 fps | 29% |
| | 4.1 | 580 fps | 26% |
| HERCO | Max. 5.1 | 852 fps | 33% |
| | 4.6 | 767 fps | 29% |
| | 4.1* | 682 fps | 26% |
| HS 6 | Max. 7.0 | 932 fps | 45% |
| | 6.5 | 857 fps | 42% |
| | 6.0* | 782 fps | 38% |
| AA-No. 5 (Most Accurate Powder Tested) | Max. 6.3 | 840 fps | 40% |
| | 5.8 | 760 fps | 37% |
| | 5.3* | 680 fps | 34% |
| IMR 4227 | Max. 10.3 | 850 fps | 66% |
| | 9.8 | 800 fps | 63% |
| | 9.3* | 740 fps | 59% |

Use Maximum Loads with Caution

.38 SPECIAL - NOSLER BULLETS

Nosler
158 Grain



158 gr.
Hollow Point

*Most Accurate Load Tested

**Compressed Load

Ballistic Coefficient .182

Sectional Density .177

| Powder | Charge Weight in Grains | Muzzle Velocity (fps) | Load Density |
|--|-------------------------|-----------------------|--------------|
| BULLSEYE | Max. 4.1* | 830 fps | 27% |
| | 3.6 | 730 fps | 24% |
| | 3.1 | 630 fps | 20% |
| WST | Max. 3.6* | 692 fps | 24% |
| | 3.1 | 577 fps | 20% |
| | 2.6 | 462 fps | 17% |
| AA-No. 2 | Max. 4.0 | 760 fps | 26% |
| | 3.5 | 680 fps | 23% |
| | 3.0* | 600 fps | 20% |
| W 231 | Max. 4.0 | 672 fps | 26% |
| | 3.5 | 567 fps | 23% |
| | 3.0* | 462 fps | 20% |
| AA-No. 5 | Max. 6.2* | 840 fps | 41% |
| | 5.7 | 750 fps | 38% |
| | 5.2 | 660 fps | 34% |
| HS 6 (Most Accurate Powder Tested) | Max. 6.9 | 890 fps | 45% |
| | 6.4 | 800 fps | 42% |
| | 5.9* | 710 fps | 39% |
| H 4227 | Max. 10.1* | 898 fps | 66% |
| | 9.6 | 843 fps | 63% |
| | 9.1 | 788 fps | 60% |

Use Maximum Loads with Caution



When You Need *ALL* the Facts...

The Sierra 4th Edition Reloading Manuals have the information you need. Rifle and Handgun reloading information are in two separate volumes, and each one covers its subject thoroughly. No matter what brand of bullet, powder, or primer you like to use, the Sierra manuals give you the full story.

They also help you with practical tips on hunting and target shooting reloading specialties from the people who are recognized as top-flight experts—like Bob Milek on loads for handgun hunters or David Tubb for big bore target rifle.

Available at your reloading retailer or call direct 1-800-223-8799. When you reload with Sierra, you reload with the Bulletsmiths®!

SIERRA

The Bulletsmiths®

Here's everything you
need to know about
your toughest reloading
problems...

1-800-223-8799

That's the Sierra Bullets TOLL-FREE Tech Line. Our Bulletsmiths[®] are on hand from 7 am to 4 pm Central Time, Monday through Friday, ready to answer your reloading questions. No matter what brand of powder or bullet, no matter the caliber or conditions, the Bulletsmiths[®] can help you develop the load to suit your need.

So don't be bashful, go ahead and give us a call.

SIERRA
The Bulletsmiths[®]

38 Special

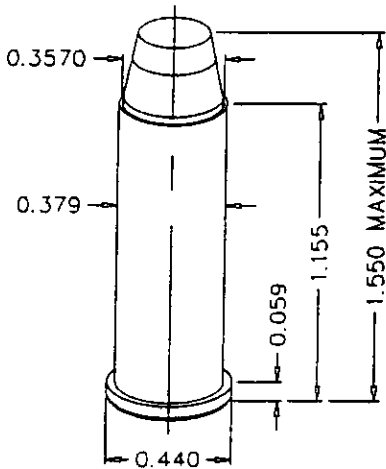

Test Specifications/ Components

Firearm Used: Smith & Wesson K-38

Barrel Length: 6"

Twist: 1 x 18 3/4"

Case: Starline

Trim-to Length: 1.150"

Primer: CCI-500 & *CCI-550

Remarks:

Introduced in 1902, the .38 Special has become one of our all time classic revolver cartridges. The case itself is an outgrowth of the old .38 Long Colt, infamous for its failure to effectively stop the charging Moros during the Philippine insurrection of 1898-1901. Although the army shifted back to a .45

caliber sidearm as a result of this experience, the .38 Long Colt underwent a major face lift as well. Doomed to obsolescence as a military cartridge, it spawned what was to become the most popular revolver cartridge ever; the .38 Special.

With legions of police officers and target shooters, the .38 Special is probably the most frequently reloaded revolver cartridge in the United States. After serving as our number one police cartridge for many decades, it has begun to slip from favor for law enforcement duties. It is slowly being replaced by more powerful numbers such as the .357 Magnum, and pistols offering greater fire-power such as the 9mm Luger. However, even in the face of newer advancements, the .38 is still the standard issue duty weapon for a great many law enforcement agencies.

The .38 Special has earned a well deserved reputation for superb accuracy. It is an incredibly well balanced cartridge, working well with a wide variety of component combinations. For this reason, it is generally regarded as the easiest of all handgun cartridges to reload. In this respect, it is an ideal first cartridge for the novice handloader. Fast to medium-fast burning powders, such as Bullseye, 231, and Unique are generally excellent choices for the .38 Special. As with any other cartridge to be used in a revolver, the .38 Special requires a roll or profile crimp for best results. Despite its age, the .38 Special is still one of the most versatile and useful cartridges in existence, and will be with us for many years to come.

.38 SPECIAL - SIERRA BULLETS

38 Special continued

#8300 .357" 110 gr. JHC
C.O.A.L. 1.450"



| Powder i / Velocity -- | 1000 | 1050 | 1100 | 1150 | 1200 |
|------------------------|------|------|------|------|------|
| Bullseye | 4.8 | 5.1 | 5.4 | | |
| 231 | 5.2 | 5.6 | 6.0 | | |
| AA-No. 2 | 5.6 | 5.8 | | | |
| Viht N320 | 5.1 | 5.4 | 5.7 | 6.0 | 6.4 |
| AA-No. 5 | | 8.6 | 8.8 | 9.0 | 9.3 |
| Unique | 5.8 | 6.2 | 6.6 | 7.0 | |
| *HS-6 | | 6.7 | 7.3 | 7.9 | 8.5 |
| Viht N340 | 6.2 | 6.5 | 6.8 | 7.1 | 7.3 |
| Viht 3N37 | 6.9 | 7.2 | 7.5 | 7.8 | 8.1 |
| *Blue Dot | 8.8 | 9.2 | 9.6 | 10.0 | 10.4 |
| Energy/ft.lbs. | 244 | 269 | 295 | 323 | 352 |

| | Powder | Grains | Velocity | Ft. lbs. |
|---------------|--------|--------|----------|----------|
| Accuracy Load | Unique | 6.6 | 1100 | 295 |
| Hunting Load | *HS-6 | 8.5 | 1200 | 352 |

#8310 .357" 125 gr. JSP
C.O.A.L. 1.450"



#8320 .357" 125 gr. JHC
C.O.A.L. 1.450"



| Powder i / Velocity -- | 900 | 950 | 1000 | 1050 | 1100 | 1150 |
|------------------------|------|------|------|------|------|------|
| Bullseye | 4.6 | 4.9 | 5.1 | | | |
| 231 | 4.8 | 5.3 | 5.8 | | | |
| AA-No. 2 | 5.0 | 5.3 | 5.6 | | | |
| Viht N320 | 4.8 | 5.1 | 5.4 | 5.7 | 5.9 | |
| AA-No. 5 | 6.4 | 7.0 | 7.6 | 8.2 | | |
| Unique | 5.2 | 5.6 | 6.0 | 6.4 | 6.8 | |
| Univ. Clays | 5.9 | 6.1 | 6.3 | 6.5 | 6.7 | |
| WAP | 6.7 | 7.0 | 7.4 | 7.8 | | |
| *HS-6 | 6.6 | 6.9 | 7.2 | 7.5 | 7.8 | 8.1 |
| *Blue Dot | | 8.4 | 8.9 | 9.4 | | |
| iMR-4227 | 13.5 | 14.2 | | | | |
| Energy/ft.lbs. | 225 | 250 | 278 | 306 | 336 | 367 |

| | Powder | Grains | Velocity | Ft. lbs. |
|---------------|--------|--------|----------|----------|
| Accuracy Load | Unique | 6.0 | 1000 | 278 |
| Hunting Load | *HS-6 | 8.1 | 1150 | 367 |

INDICATES MAXIMUM LOAD - USE CAUTION
LOADS LESS THAN MINIMUM CHARGES SHOWN ARE NOT RECOMMENDED.

.38 SPECIAL - SIERRA BULLETS

38 Special continued

#8325 .357" 140 gr. JHC
C.O.A.L. 1.450"



| Powder/Velocity - | 850 | 900 | 950 | 1000 | 1050 |
|-------------------|-----|------|------|------|------|
| Bullseye | 4.5 | 4.8 | 5.1 | | |
| 231 | 4.9 | 5.2 | 5.6 | | |
| AA-No. 2 | 4.6 | 5.0 | 5.4 | | |
| Unique | 5.6 | 5.9 | 6.2 | 6.4 | |
| Univ. Clays | 5.7 | 5.9 | 6.1 | 6.3 | 5.6 |
| AA-No. 5 | 7.3 | 7.6 | 7.9 | 8.1 | |
| *HS-6 | 6.0 | 6.4 | 6.7 | 7.1 | 7.4 |
| Viht 3N37 | 6.4 | 6.6 | 6.9 | 7.1 | 7.4 |
| *Blue Dot | 7.4 | 7.8 | 8.2 | 8.6 | |
| Viht N350 | 6.1 | 6.3 | 6.5 | 6.7 | 7.0 |
| *2400 | | 9.7 | 10.4 | 11.0 | |
| IMR-4227 | | 12.2 | 12.8 | 13.4 | |
| Energy/ft.lbs. | 225 | 252 | 281 | 311 | 343 |

| | Powder | Grains | Velocity | Ft. lbs. |
|---------------|----------|--------|----------|----------|
| Accuracy Load | AA-No. 5 | 7.9 | 950 | 281 |
| Hunting Load | *HS-6 | 7.4 | 1050 | 343 |

INDICATES MAXIMUM LOAD - USE CAUTION
LOADS LESS THAN MINIMUM CHARGES SHOWN ARE NOT RECOMMENDED.

.38 SPECIAL - SIERRA BULLETS

38 Special continued

#8360 .357" 158 gr. JHC
C.O.A.L. 1.450"



#8340 .357" 158 gr. JSP
C.O.A.L. 1.450"



| Powder/Velocity -- | 750 | 800 | 850 | 900 | 950 | 1000 |
|--------------------|-----|------|------|------|------|------|
| Bullseye | 3.4 | 4.1 | 4.9 | | | |
| 231 | 4.1 | 4.5 | 4.9 | | | |
| AA-No. 2 | 4.2 | 4.5 | 4.8 | | | |
| AA-No. 5 | 6.6 | 6.8 | 7.1 | 7.4 | | |
| Unique | 5.0 | 5.4 | 5.7 | 6.1 | | |
| Viht N340 | 5.0 | 5.2 | 5.5 | 5.7 | 5.9 | 6.2 |
| *HS-6 | | 5.6 | 6.0 | 6.4 | 6.8 | 7.2 |
| *Blue Dot | | 7.4 | 7.8 | 8.2 | | |
| Viht N350 | 5.4 | 5.7 | 6.1 | 6.4 | 6.7 | 7.1 |
| *2400 | | | 8.9 | 9.6 | 10.3 | |
| *296 | | | 10.6 | 11.1 | 11.6 | 12.1 |
| IMR-4227 | | 10.4 | 11.2 | 12.0 | 12.8 | |
| Energy/ft.lbs. | 197 | 224 | 253 | 284 | 317 | 351 |

| | Powder | Grains | Velocity | Ft. lbs. |
|---------------|--------|--------|----------|----------|
| Accuracy Load | Unique | 5.7 | 850 | 253 |
| Hunting Load | *HS-6 | 7.2 | 1000 | 351 |

INDICATES MAXIMUM LOAD - USE CAUTION
LOADS LESS THAN MINIMUM CHARGES SHOWN ARE NOT RECOMMENDED.

.38 SPECIAL - SIERRA BULLETS

38 Special *continued*

#8365 .357" 170 gr. JHC
C.O.A.L. 1.450"



#8350 .357" 170 gr. FMJ Match
C.O.A.L. 1.450"



| Powder†/Velocity -- | 750 | 800 | 850 | 900 | 950 |
|---------------------|-----|------|------|------|------|
| Unique | 4.9 | 5.1 | 5.3 | 5.5 | |
| *HS-6 | | 5.5 | 6.0 | 6.5 | 7.0 |
| Viht N340 | 5.0 | 5.2 | 5.5 | 5.7 | 6.0 |
| *AA-No. 7 | 7.8 | 8.1 | 8.4 | 8.7 | 9.0 |
| Viht N350 | 5.4 | 5.7 | 6.0 | 6.3 | 6.5 |
| *Blue Dot | | | 6.9 | 7.3 | 7.7 |
| *2400 | | 9.2 | 9.9 | 10.6 | |
| *296 | | | 10.8 | 11.4 | 11.8 |
| IMR-4227 | | 11.2 | 11.7 | 12.2 | |
| Energy/ft.lbs. | 212 | 242 | 273 | 306 | 341 |

| | Powder | Grains | Velocity | Ft. lbs. |
|---------------|-----------|--------|----------|----------|
| Accuracy Load | Unique | 5.3 | 850 | 273 |
| Hunting Load | *AA-No. 7 | 9.0 | 950 | 341 |

#8370 .357" 180 gr. FPJ Match
C.O.A.L. 1.430"



| Powder†/Velocity -- | 700 | 750 | 800 | 850 |
|---------------------|-----|------|------|------|
| Unique | 4.7 | 4.9 | 5.1 | 5.3 |
| Viht N340 | 4.8 | 5.0 | 5.3 | 5.6 |
| *AA-No. 7 | 7.3 | 7.6 | 7.9 | 8.3 |
| Viht N350 | 5.6 | 5.8 | 6.1 | 6.4 |
| *Blue Dot | 6.2 | 6.5 | 6.8 | 7.1 |
| *2400 | 8.0 | 8.4 | 8.8 | 9.1 |
| *296 | | 9.1 | 9.6 | 10.1 |
| IMR-4227 | 9.7 | 10.1 | 10.4 | 10.7 |
| Energy/ft.lbs. | 196 | 225 | 256 | 289 |

| | Powder | Grains | Velocity | Ft. lbs. |
|---------------|-----------|--------|----------|----------|
| Accuracy Load | *AA-No. 7 | 7.9 | 800 | 256 |
| Hunting Load | *296 | 10.1 | 850 | 289 |

INDICATES MAXIMUM LOAD - USE CAUTION
LOADS LESS THAN MINIMUM CHARGES SHOWN ARE NOT RECOMMENDED.

SPEER®

SPEER®

SPEER®

SPEER®

SPEER™ HAS A MORE POTENT RECIPE FOR PUNCH.

JACKET OPENING ENGINEERED FOR RELIABLE EXPANSION, EVEN AT LOW VELOCITIES.

DOUBLE-SWAGED FOR TIGHT DIAMETER CONTROL AND IMPROVED ACCURACY.

"SOLDER-TYPE" BOND OF LEAD CORE TO JACKET.

MOLTEN 1.5% ANTIMONY LEAD IS Poured INTO JACKET, UNIFYING CORE AND JACKET.

HEAVY JACKET IS 45.6% THICKER THAN OLD DESIGN, GIVING BULLET GREATER STRENGTH AND WEIGHT RETENTION DURING IMPACT AT HIGH VELOCITIES.

THE IMPROVED 165 GRAIN — .308" HOT-COR™ BULLET.



308, 165 GR
72% RETAINED
WEIGHT SHOT INTO
BALLISTIC TEST MEDIA

The secret of its success—Hot-Cor.™ Our own special process that injects molten lead into the jacket, rather than forcing in a cold lead slug. The result: greater expansion and weight retention than conventional "cold core" bullets. With deadly accuracy and consistency. Shot after shot after shot.



SPEER®

YOUR SHOOTING PARTNER.

CCI • SPEER • RCBS • OUTERS • WEAVER

.38 SPECIAL - SPEER BULLETS

At Standard Pressures

In terms of revolvers sold and number of cartridges reloaded, the 38 Special is probably at the top of the stack. This is one of the most widely accepted cartridges ever. 38 Special revolvers are manufactured and used around the world.

Smith & Wesson introduced the 38 Special in 1902 as a ballistic improvement over the 38 Long Colt cartridge. The new cartridge was somewhat more powerful but much of its acceptance was due to its excellent accuracy compared with other medium-caliber revolver cartridges of the period. Originally loaded with black powder, the cartridge was quickly converted to smokeless as the new propellants became available.

The original cartridge used a 158 grain lead round nose bullet, a design that remains with us today. Wadcutters were also loaded to cut clean, full-caliber holes in paper targets. Other than handful of specialty loads for law enforcement, these two bullets were just about the only choices in factory ammunition until the late 1960's when expanding jacketed bullets were introduced.

During the 1930's demand for better 38 Special performance led to the introduction of heavy-frame revolvers designed to handle 158 grain bullets at higher velocities—up to 1000 feet/sec. Thus, two pressure levels existed in the industry for years. Obviously, having ammo available with two pressures levels presented a problem. Lighter revolvers could eventually loosen if they fired too many high-pressure cartridges. There was little uniformity in case markings, meaning you couldn't tell a high-pressure load by looking at the cartridge.

This confusion was finally eliminated in 1974 when the industry instituted the +P (plus

pressure) headstamp designator to identify cartridges loaded to the higher pressure limit. Since all U.S. ammo makers and most foreign ones agreed to use this system, the shooter could simply look at a factory cartridge and tell the pressure level.

Because there are differences in the reloading of 38 Special and 38 Special +P cartridges, we have listed data for this cartridge in separate sections. The section on +P loads immediately follows this one.

Reloaders must remember that the 38 Special started life as a black powder cartridge. Thus, the case is much bigger than necessary for most modern propellants. A maximum-pressure charge of some powders takes up very little room in the case. Air space is high, especially when loading standard (not +P) loads.

Lead bullets are usually best for loading standard pressure 38 Specials. They are easily propelled through the barrel by modest powder charges. Jacketed bullets create more resistance than lead bullets and can actually stick in the bore with charges that are too light. This condition is aggravated in revolvers with large chamber throats or excessive barrel/cylinder gaps. To avoid these problems, we are showing jacketed bullet data for only the 110 and 125 grain bullets. Heavier bullets may not attain sufficient velocity to reliably overcome friction. Note that these loads are marked "DNR" meaning "do not reduce." Reductions of loads below the levels shown can result in a bullet-in-bore condition in revolvers with excessive barrel/cylinder gaps. **THESE JACKETED BULLET LOADS MUST NOT BE USED IN RIFLES.**

We developed new loads for Cowboy Action shooting using bullets cast from the RCBS 9mm-

.38 SPECIAL - SPEER BULLETS

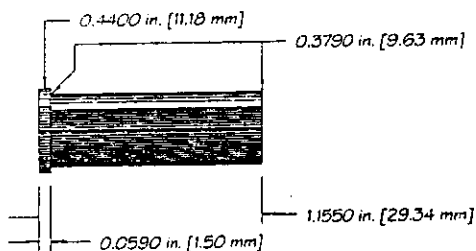

Max. Case Length: 1.155" Test Firearm: Smith & Wesson Model 14
 Trim-to Length: 1.145" Case: Speer
 Max. Cart. Length: 1.550" Primers: CCI 500, 550
 RCBS Shellholder: #6
 Barrel Length: 6"
 Twist: 1-18.75"



38 Caliber Cast Bullets

147 Grain
Sect. Density 167

9mm-147
FN

NOTE: Seat to and roll-cripp into the front lube groove.

| Powder | Wt. Grs. | Mzl.Vel. | Powder | Wt. Grs. | Mzl.Vel. | Powder | Wt. Grs. | Mzl.Vel. |
|--------------------|------------|------------|------------------|------------|------------|----------------|------------|------------|
| Lead Alloy | hard | | | | | | | |
| Diameter Sized | 0.358" | | | | | | | |
| Ballistic Coef. | 0.151 | | | | | | | |
| C. O. L. Tested At | 1.540" | | | | | | | |
| RCBS Mould No. | 82077 | | | | | | | |
| 700-X | 3.8 | 893 | H. | 4.4 | 846 | WSF | 4.2 | 836 |
| | 3.2 | 780 | Universal | 4.0 | 765 | | 3.8 | 753 |
| AA | 4.0 | 871 | | 4.2 | 840 | | 4.6 | 820 |
| #2 Impr. | 3.5 | 803 | PB | 3.7 | 761 | Unique | 4.0 | 741 |
| | 4.0 | 852 | | 3.5 | 838 | | 3.4 | 794 |
| HP-38 | 3.6 | 768 | Bullseye | 3.1 | 768 | Red Dot | 3.0 | 716 |

Notes: Bold print denotes maximum loads. They should be used with caution.

We sell bullet moulds, not cast bullets.
 These bullets were cast in RCBS moulds.
 Contact your dealer for more information
 on the RCBS line of premium moulds.

.38 SPECIAL - SPEER BULLETS



NOTE: Seat bullets flush with case mouth. Use a light roll or taper crimp.

.358" Dia. 148 Grain

Sect. Density .166

| | .38 HB-WC | | | | |
|-----------------------|--------------|--|--|--|--|
| Ballistic Coefficient | 0.050 | | | | |
| C.O.L. Tested At | see note | | | | |
| Speer Part No. | 4617 | | | | |

| Powder | Wt. Grs. | Mzl. Vel. | Powder | Wt. Grs. | Mzl. Vel. | Powder | Wt. Grs. | Mzl. Vel. |
|----------------|----------|-----------|-----------------|----------|-----------|--------------|----------|-----------|
| | 3.0 | 806 | | 3.2 | 801 | | 2.9 | 791 |
| Red Dot | 2.7 | 754 | HP-38 | 2.9 | 752 | 700-X | 2.6 | 739 |
| | 3.3 | 804 | | 3.1 | 799 | | 3.1 | 789 |
| 231 | 3.0 | 749 | Bullseye | 2.8 | 741 | AA #2 | 2.7 | 690 |

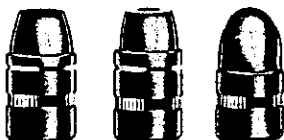

.358" Dia. 158 Grain

Sect. Density .175

| | .38 L-SWC | .38 L-HP | .38 L-RN | | |
|-----------------------|--------------|-------------|-------------|--|--|
| Ballistic Coefficient | 0.123 | 0.121 | 0.170 | | |
| C.O.L. Tested At | 1.440" | 1.455" | 1.510" | | |
| Speer Part No. | 4623 | 4627 | 4647 | | |

| Powder | Wt. Grs. | Mzl. Vel. | Powder | Wt. Grs. | Mzl. Vel. | Powder | Wt. Grs. | Mzl. Vel. |
|---------------------|----------|-----------|-------------------|----------|-----------|--------------------|----------|-----------|
| SR | 5.6 | 967 | | 4.3 | 863 | | 4.7 | 815 |
| 4756 | 5.0 | 844 | 231 | 3.8 | 783 | Unique | 4.0 | 740 |
| | 5.4 | 948 | | 4.2 | 858 | | 3.5 | 814 |
| Power Pistol | 4.8 | 856 | PB | 3.7 | 770 | Bullseye | 3.1 | 752 |
| | 6.2 | 922 | | 4.1 | 855 | | 3.4 | 793 |
| AA #5 | 5.8 | 874 | HP-38 | 3.6 | 756 | Red Dot | 3.0 | 727 |
| | 4.6 | 902 | | 4.3 | 830 | | 4.0 | 781 |
| H. Universal | 4.2 | 827 | WSF | 3.8 | 738 | AA #2 Impr. | 3.6 | 708 |
| | 3.8 | 877 | | 5.0 | 818 | | | |
| 700-X | 3.2 | 774 | Viht. N350 | 4.5 | 717 | | | |

Notes: Bold print denotes maximum loads. They should be used with caution.
* CCI Magnum Primer used with this powder.

.38 SPECIAL - SPEER BULLETS



**.357" Dia.
125 Grain**

Sect. Density .140

| | 38 JSP | 38 GD-HP | 38 JHP | 38 TMJ | | |
|-----------------------|-----------|-------------|-----------|-----------|--|--|
| Ballistic Coefficient | 0.140 | 0.140 | 0.135 | 0.146 | | |
| C.O.L. Tested At | 1.435" | 1.470" | 1.435" | 1.435" | | |
| Speer Part No. | 4011 | 4012 | 4013 | 4015 | | |

| Powder | Wt. Grs. | Mzl.Vel. | Powder | Wt. Grs. | Mzl.Vel. | Powder | Wt. Grs. | Mzl.Vel. |
|-----------------|----------|----------|----------------|----------|----------|--------------------|----------|----------|
| AA | 7.8 | 1053 | H. | 5.6 | 976 | | 4.9 | 927 |
| #5 | DNR | — | Universal | DNR | — | PB | DNR | — |
| Viht. | 6.8 | 1037 | | 4.8 | 949 | | 4.5 | 914 |
| 3N37 | DNR | — | WSL | DNR | — | Bullseye | DNR | — |
| AA | 5.4 | 994 | | 5.6 | 944 | | 4.6 | 905 |
| #2 Impr. | DNR | — | 231 | DNR | — | 700-X | DNR | — |
| Power Pistol | 6.1 | 986 | | 5.3 | 934 | American Select | 4.1 | 839 |
| | DNR | — | WSF | DNR | — | | DNR | — |
| | 5.7 | 980 | | 4.4 | 933 | | | |
| Unique | DNR | — | Tite- Group | DNR | — | | | |

Notes: Bold print denotes maximum loads. They should be used with caution. C - Compressed Load
* CCI Magnum Primer used with this powder.

LAB NOTES...

At 38 Special pressures, the 357-110 JHP and the 357-125 GDHP have very similar ballistic behavior because of the difference in their construction (conventional v. Uni-Cor™). That's why the loads for the two bullets are so close in charge weight. Depending on the powder, the GD may have higher charge weights than the lighter 110 grain bullet.

38 SPECIAL +P

Intended only for firearms approved by their manufacturer for +P ammo. See previous section for 38 Special loads at standard pressures.

In the 1930's, the performance of the standard 38 Special was enhanced by the addition of loads at higher operating pressures. When first conceived, these loads were intended for firing only in heavy Colt and Smith & Wesson revolvers built on 44 Special frames. Cases were sometimes headstamped "38 HV," "38 HS" or "38/44" to indicate the higher pressure. Other enhanced loads could be identified only if you had the original box or a catalog number.

To have a consistent system for identifying higher-pressure ammo, the industry adopted the +P headstamp in 1974. The three cartridges to which this identifier was first applied were the 38 Super Auto, the 257 Roberts and the 38 Special.

The current industry pressure limit for 38 Special +P ammunition is 20,000 psi, compared to 17,000 psi for the standard 38 Special. This allows a bit more flexibility for the handloader using jacketed bullets. At +P levels we can show starting loads. When loading Speer jacketed bullets, you must not use charge weights lighter than the starting loads shown here.

Even at +P velocities, best expansion is obtained with Speer's 110 and 125 grain hollow points because they permit higher velocity. Heavier bullets give less expansion but offer deeper penetration. Powders having a moderate burning rate usually give the best performance in the 38 +P. Jacketed bullets heavier than 146 grains yielded very low velocities and we no longer recommend them in the 38 Special. To fill this weight slot, we have developed new +P loads for the 158 grain Speer lead bullets. Many researchers still think the 158 grain lead hollow point beats any jacketed 38 load for expansion and penetration.

Some revolvers are not rated for 38 Special +P ammunition. Contact your firearm's manufacturer and follow their recommendation on the use of this ammunition. Firearms not approved for +P ammunition may show accelerated wear if subjected to continuous firing with +P ammo.

.38 SPECIAL - SPEER BULLETS

" + P LOADS "

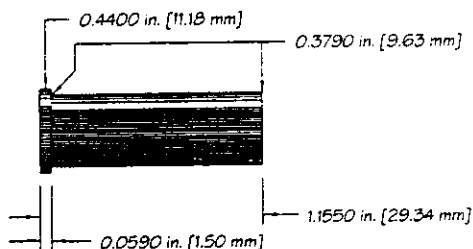

Max. Case Length: 1.155" **Test Firearm:** Smith & Wesson Model 14
Trim-to Length: 1.145" **Case:** Speer
Max. Cart. Length: 1.550" **Primers:** CCI 500, 550
RCBS Shellholder: #6
Barrel Length: 6"
Twist: 1-18.75"



.358" Dia.

158 Grain

Sect. Density .175

| | 38 L-SWC | 38 L-HP | 38 L-RN | | | |
|-----------------------|-------------|------------|------------|--|--|--|
| Ballistic Coefficient | 0.123 | 0.121 | 0.170 | | | |
| C.O.L. Tested At | 1.440" | 1.455" | 1.510" | | | |
| Speer Part No. | 4623 | 4627 | 4647 | | | |

| | Powder | Wt. Grs. | Mzl. Vel. | Powder | Wt. Grs. | Mzl. Vel. | Powder | Wt. Grs. | Mzl. Vel. |
|---------------------|--------|----------|-----------|-------------------|----------|-----------|--------------------|----------|-----------|
| Power Pistol | | 6.0 | 1037 | | 4.6 | 962 | | 4.7 | 892 |
| | | 5.4 | 948 | PB | 4.2 | 858 | WSF | 4.3 | 830 |
| | | 4.4 | 980 | | 4.7 | 935 | | 3.9 | 874 |
| 700-X | | 3.8 | 877 | 231 | 4.3 | 863 | Bullseye | 3.5 | 814 |
| | | 6.6 | 978 | | 5.2 | 919 | | 3.8 | 846 |
| AA #5 | | 6.2 | 922 | Unique | 4.7 | 815 | Red Dot | 3.4 | 793 |
| | | 6.7 | 971 | | 4.5 | 918 | | 4.3 | 843 |
| HS-6 | | 6.3 | 914 | HP-38 | 4.1 | 855 | AA #2 Impr. | 4.0 | 781 |
| | | 5.0 | 971 | | 5.4 | 901 | | | |
| Universal | | 4.6 | 902 | Viht. N350 | 5.0 | 818 | | | |

Notes: Bold print denotes maximum loads. They should be used with caution.

.38 SPECIAL - SPEER BULLETS

" + P LOADS "



.357" Dia.

110 Grain

Sect. Density .123

| | | | | | |
|-----------------------|---------------|--|--|--|--|
| | 38 JHP | | | | |
| Ballistic Coefficient | 0.122 | | | | |
| C.O.L. Tested At | 1.430" | | | | |
| Speer Part No. | 4007 | | | | |

| Powder | Wt. Grs. | Mzl. Vel. | Powder | Wt. Grs. | Mzl. Vel. | Powder | Wt. Grs. | Mzl. Vel. |
|---------------------|----------|-----------|---------------------|----------|-----------|-------------------|----------|-----------|
| | 8.5 | 1237 | | 8.2 | 1137 | | 5.4 | 1081 |
| Blue Dot | 8.2 | 1198 | AA #5 | 7.8 | 1116 | PB | 4.9 | 979 |
| H. Universal | 6.3 | 1192 | Power Pistol | 6.9 | 1135 | Tite-Group | 5.0 | 1080 |
| | 6.0 | 1134 | | 6.1 | 1028 | | 4.5 | 1009 |
| Vih. 3N37 | 7.3 | 1185 | | 5.1 | 1111 | | 4.9 | 1078 |
| | 6.9 | 1061 | Bullseye | 4.7 | 1022 | 700-X | 4.4 | 983 |
| | 6.2 | 1165 | | 5.9 | 1108 | | 6.0 | 1077 |
| Unique | 5.9 | 1097 | 231 | 5.6 | 1005 | WSF | 5.3 | 978 |



.357" Dia.

125 Grain

Sect. Density .140

| | | | | | |
|-----------------------|---------------|-----------------|---------------|---------------|--|
| | 38 JSP | 38 GD-HP | 38 JHP | 38 TMJ | |
| Ballistic Coefficient | 0.140 | 0.140 | 0.135 | 0.146 | |
| C.O.L. Tested At | 1.435" | 1.440" | 1.435" | 1.435" | |
| Speer Part No. | 4011 | 4012 | 4013 | 4015 | |

| Powder | Wt. Grs. | Mzl. Vel. | Powder | Wt. Grs. | Mzl. Vel. | Powder | Wt. Grs. | Mzl. Vel. |
|---------------------|----------|-----------|--------------------|----------|-----------|------------------------|----------|-----------|
| Vih. 3N37 | 7.2 | 1098 | | 4.8 | 1021 | | 4.9 | 1013 |
| | 6.9 | 1037 | Bullseye | 4.5 | 914 | 700-X | 4.6 | 905 |
| AA #5 | 8.1 | 1089 | | 5.4 | 1021 | Tite-Group | 4.9 | 1012 |
| | 7.8 | 1053 | PB | 4.9 | 927 | | 4.4 | 993 |
| | 6.0 | 1082 | | 5.8 | 1021 | | 5.1 | 1003 |
| Unique | 5.7 | 980 | WSF | 5.3 | 934 | WSL | 4.8 | 949 |
| | 6.8 | 1082 | | 5.9 | 1019 | American Select | 4.7 | 931 |
| Power Pistol | 6.1 | 986 | 231 | 5.6 | 944 | | 4.1 | 839 |
| | 5.9 | 1058 | | 5.7 | 1014 | | | |
| H. Universal | 5.6 | 976 | AA #2 Impr. | 5.4 | 994 | | | |

Notes: Bold print denotes maximum loads. They should be used with caution.

.38 SPECIAL - SPEER BULLETS

" + P LOADS "



**.357" Dia.
140 Grain**

Sect. Density .157

| | | | | | | | |
|-----------------------|-------------------|--|--|--|--|--|--|
| | 38 JHP | | | | | | |
| Ballistic Coefficient | 0.152 | | | | | | |
| C.O.L. Tested At | 1.435" | | | | | | |
| Speer Part No. | 4203 | | | | | | |

| Powder | Wt. Grs. | Mzl. Vel. | Powder | Wt. Grs. | Mzl. Vel. | Powder | Wt. Grs. | Mzl. Vel. |
|-------------------------|----------|-----------|------------------|----------|-----------|------------------------|----------|-----------|
| | 7.4 | 1053 | | 5.5 | 974 | | | |
| Blue Dot | 7.1 | 1024 | WSF | 5.3 | 930 | SR 4756 | 5.9 | 933 |
| AA | 7.1 | 1002 | H. | 5.3 | 969 | | 5.1 | 931 |
| #5 | 6.8 | 955 | Universal | 5.0 | 935 | 231 | 4.8 | 870 |
| Viht. | 6.2 | 982 | | 5.3 | 960 | | 4.6 | 924 |
| N350 | 5.9 | 924 | Unique | 5.0 | 902 | Bullseye | 4.0 | 828 |
| Power Pistol | 6.0 | 976 | | 7.0 | 960 | Tite- Group | 4.2 | 883 |
| | 5.3 | 872 | HS-6 | 6.4 | 873 | | 3.7 | 819 |



NOTE: NEVER load this bullet with charges lighter than shown here.

**.357" Dia.
146 Grain**

Sect. Density .163

| | | | | | | | |
|-----------------------|-----------------------|--|--|--|--|--|--|
| | 38 JHP-SWC | | | | | | |
| Ballistic Coefficient | 0.159 | | | | | | |
| C.O.L. Tested At | 1.370" | | | | | | |
| Speer Part No. | 4205 | | | | | | |

| Powder | Wt. Grs. | Mzl. Vel. | Powder | Wt. Grs. | Mzl. Vel. | Powder | Wt. Grs. | Mzl. Vel. |
|-----------------|----------|-----------|-------------------------|----------|-----------|--------------|----------|-----------|
| AA | 8.2 | 1004 | | 9.0 | 952 | Viht. | 5.6 | 903 |
| #7 | 7.8 | 937 | 2400 | 8.3 | 836 | N350 | 5.2 | 840 |
| | 7.1 | 1000 | H. | 5.0 | 940 | | 4.5 | 845 |
| Blue Dot | 6.7 | 971 | Universal | 4.6 | 894 | 231 | DNR | — |
| | 5.1 | 957 | | 5.5 | 935 | | | |
| Unique | 4.8 | 905 | Power Pistol | 4.9 | 832 | | | |

Notes: Bold print denotes maximum loads. They should be used with caution.
DNR — do not reduce

THE ALL-IN-ONE RELOADING KIT

also covers
handloading

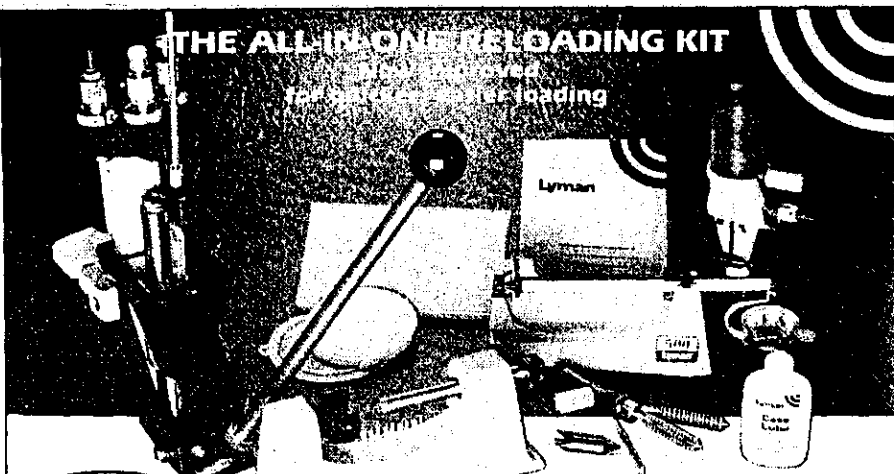

Features
Qwik-Disconnect
Turret System

Make Custom Ammo Today
with One Easy Purchase

Our popular Expert Kit is now even better since we upgraded to the versatile T-MAG Press. Combines the speed of a turret press with the strength and ease of compound leverage. Accepts all std. 7/8" x 14 dies. Removable turret holds up to 6 dies for easy set-up and storage.

This Kit combines everything needed to load quality pistol or rifle ammunition except the components. Available with or without a die set.

Lyman's Expert Kit includes:

- T-Mag Press complete
- Universal® case trimmer and Pilot Pack
- Model 500 Powder Scale
- Model 55 Powder Measure
- Misc. accessories and case prep gear
- "How To" Reloading Guide

Interested in Handloading? Save money and time! Ask for the Lyman Expert Kit. Available at your dealer today!

Write for free mini-catalog.

Questions?
Call toll free 1-800-22-LYMAN.

Lyman Dept 000, Route 147
Middlefield, CT 06455

NEW PRODUCTS REPORT

CAST YOUR OWN

And cast high cost to the wind

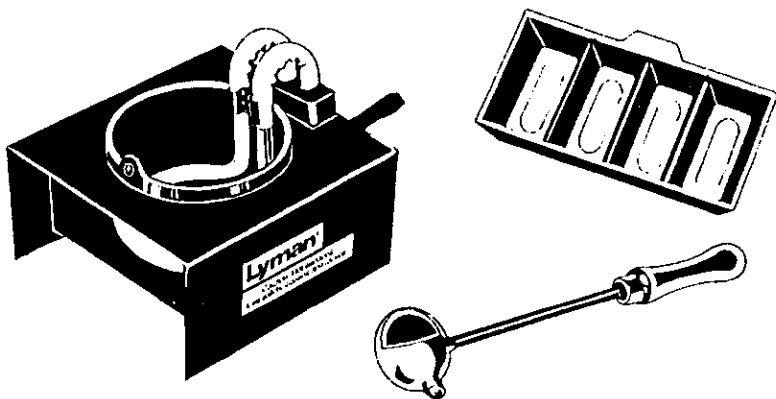

Enjoy the satisfaction of casting your own bullets, fishing jigs or sinkers. The fully electric **Mini-Mag Furnace** features a long life, heavy duty heating coil that will give you years of quality melting.

The **Mini-Mag Furnace** is designed for use with a ladle and has an operating capacity of 8 lbs. It reaches a temperature of over 700° in about 20 minutes and the stable metal base can be used as a pre-heater for mould blocks. The furnace comes with a 3 prong safety cord.

It is the best capacity value available today. Try Lyman and cast with confidence.

See your Lyman dealer for our complete line of casting equipment. Also available direct for \$39.95 postpaid. Send check or money order. Visa/MC accepted. Write for free mini-catalog.

Questions? Call toll free 1-800-22-LYMAN

Lyman*

Dept 000, Route 147 Middlefield, CT 06455

.38 SPECIAL - LYMAN BULLETS

Reloading Data Introduction:

The data listed in this section have been tested by our technicians and found to be safe when loaded with our test components and fired (under our laboratory controlled conditions) in our testing equipment. Since Lyman Products Corporation has no control over the manufacture of the various components listed, the actual loading, choice or condition of the firearms and components used, no responsibility for use of this data is implied or assumed.

Components:

The reader should bear in mind that the components listed are not of Lyman manufacture. Therefore, it is impossible that production changes affecting ballistic performance can occur at any time without our knowledge. If there is ever a question as to the correctness of the component specified, write to its manufacturer.

Starting Load:

It is essential that the reader begin with the suggested weight of powder listed in this bracket and work up slowly (following load development precautions) to his best performing load. The novice should use only the "starting load" for a period of time until he builds confidence and experience. Never decrease this charge as an increase in pressure could be encountered.

Maximum Load:

All loads which are listed as maximum were tested and classified as maximum by our technicians in accordance with our laboratory standards. Under no circumstances should these loads be exceeded, nor should they be quickly accepted by the reader as a safe working maximum for his particular rifle or pistol.

Many reloaders misinterpret the meaning of the "maximum load." They wrongly assume that if a high pressure load proved safe in a test laboratory then it is equally safe under any and all conditions. This is not true. The reader must start with the "starting load" and work up his load carefully. Working with his particular firearm and component combination, he may encounter signs of excess pressure before he reaches the maximum charge listed.

The technician classifies a load as maximum after carefully considering many aspects of its ballistic performance. The maximum average pressure of the load is not the only criteria. Often a load having an acceptable maximum average pressure will be rejected (or reduced) due to its erratic performance. Accuracy must also be considered, particularly when dealing with cast lead alloy bullets. In all instances, the maximum listing represents what our technicians consider to be the maximum working combination for the bullet, powder and caliber listed. These loads do not exceed SAAMI standards.

Accuracy Loads:

When a load is noted as such in the data tables proper, it means that the given combination of components produced the most uniform internal ballistics of any load tested utilizing that particular bullet design.

.38 SPECIAL - LYMAN BULLETS

Unless noted in "Comments," the accuracy load was not fired at targets. The load, however, does have a high potential—assuming all external factors are optimum—for producing outstanding accuracy since uniform internal ballistics are critical to accuracy on target. You cannot have one without the other.

Test Parameters:

Velocities shown were taken at fifteen feet and not corrected to the muzzle.

Each test string began with a clean dry barrel and consisted of ten shots.

Loads exhibiting erratic internal ballistics were not pursued.

We had no problem with leading in any of our testing.

Bullets:

Bullet numbers are listed in the introductory specifications for each cartridge and in the headline above the appropriate data block—along with an illustration of that particular bullet.

Please note these bullets are artists' rendering. Comparing your bullet against the drawing could reveal minor differences. Furthermore, minor changes are sometimes made to bullets. These drawings, which appear throughout the data sections, are for general reference only and are not intended to be a precise representation.

Bullet alloy is noted as is the exact weight of each tested bullet.

Not all cast bullets within a given caliber are intended to perform equally. We have used them in the most appropriate chamberings.

Powders:

We have limited our testing to those powders which are manufactured in the United States and which are readily available to the consumer. The following brands are listed: Dupont (now IMR), Winchester, Hercules, Alcan, Hodgdon and Gearhart-Owen.

Compressed Loads:

All compressed loads are indicated with a +. Depending upon the volume of the specific cartridge case used by the reader, he may, or may not, have difficulty starting bullets in such loads. If the bullet will not start, reduce the load sufficiently so that 1/10" of space remains in the case neck. Start the bullet into the case and use whatever additional pressure is required to fully seat the bullet. Failure to comply could result in a bulged case.

Filler Wads:

Dacron filler wads in the form of 1/4-inch thick batting were used in conjunction with cast bullet loads, where indicated. This material can be purchased in most yard-goods stores. It should be cut into squares, which seal the case.

When developing a load, if a wad is desired, its should be used from the beginning as the charge weight is increased. It should never be added as an afterthought, once a maximum load has been established, since its presence could result in a pressure increase of 2,000 CUP or more.

.38 SPECIAL - LYMAN BULLETS

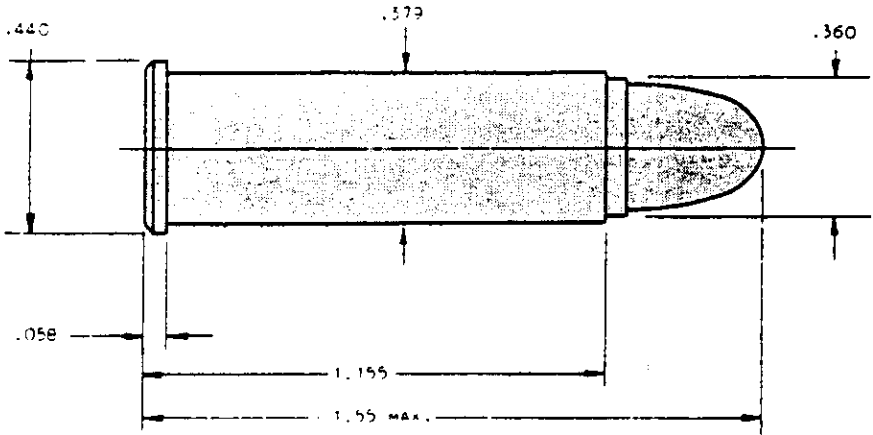

COMMENTS:

Loads designated with a +P symbol are higher pressure loads and must not be used in standard 38 Special revolvers unless the firearm manufacturer has suggested the use of such ammunition in your specific revolver. This caution should not be ignored. Under no circumstance should +P (plus P) ammo be used in revolvers with aluminum frames and/or aluminum cylinders.

Do not use charge weights below the starting load to prevent bullet jackets from half jacket bullets from becoming lodged in the barrel (the lead cores may exit the muzzle and strike the target). To crimp half jacket bullets, form the crimp at the junction of the jacket and exposed lead nose.

For target (mid-range) loads we suggest bullet #358495 with the suggested starting grains load. Bullet #358311 duplicates the factory lead round nose 158 grain bullet very closely. Bullet #358429 closely duplicates the factory 158 grain semi-wadcutter. This is the Elmer Keith design bullet and makes an excellent choice for hunting.

Handguns can vary in groove diameter and it is wise to slug your barrel before sizing cast bullets.

Hercules Bullseye and Winchester 231 consistently provide the best accuracy with all bullets.

.38 SPECIAL - LYMAN BULLETS



#356242

121 gr. (Linotype) 1.450" OAL

| POWDER | Sugg. Starting Grains | Velocity fps | Pressure C.U.P. | Max. Load Grains | Velocity fps | Pressure C.U.P. |
|----------|-----------------------|--------------|-----------------|------------------|--------------|-----------------|
| 700X | 2.5 | 647 | 7,600 | 3.9 | 940 | 16,200 |
| | | | | (+P)4.2 | 987 | 17,900 |
| SR-7625 | 4.0 | 788 | 10,600 | 5.0 | 988 | 16,200 |
| Bullseye | 2.8 | 690 | 8,600 | 4.6 | 1001 | 16,400 |
| | | | | (+P)4.9 | 1045 | 18,400 |
| Red Dot | 3.3 | 749 | 10,100 | 4.6 | 974 | 16,200 |
| | | | | (+P)5.0 | 1047 | 18,400 |
| Unique | 4.0 | 725 | 9,000 | 5.7 | 1012 | 16,200 |
| 231 | 3.4 | 693 | 8,800 | 5.1 | 986 | 16,600 |
| | | | | (+P)5.4 | 1036 | 17,900 |
| HP38 | 3.0 | 725 | 9,600 | 4.3 | 961 | 16,700 |
| | | | | (+P)4.8 | 1045 | 18,300 |



#358495

141 gr. (Linotype) 1.310" OAL

| POWDER | Sugg. Starting Grains | Velocity fps | Pressure C.U.P. | Max. Load Grains | Velocity fps | Pressure C.U.P. |
|----------|-----------------------|--------------|-----------------|------------------|--------------|-----------------|
| 700X | 2.2 | 636 | 8,300 | 4.0 | 994 | 16,600 |
| SR-7625 | 3.1 | 683 | 9,100 | 4.3 | 905 | 15,600 |
| Bullseye | 3.0 | 778 | 11,000 | 4.1 | 973 | 16,800 |
| Red Dot | 2.8 | 706 | 9,500 | 4.2 | 961 | 16,300 |
| Unique | 3.8 | 757 | 10,300 | 5.3 | 1013 | 16,700 |
| 231 | 3.0 | 667 | 8,500 | 4.9 | 1001 | 16,800 |
| HP38 | 2.7 | 683 | 9,000 | 4.5 | 1001 | 16,800 |
| AA 2 | 2.7 | 788 | 12,200 | 3.5 | 934 | 16,300 |
| Clays | 2.7 | 769 | 11,600 | 2.8 | 905 | 16,200 |

Note: Loads shown in shaded panels are maximum.
 (+P) Designates higher pressure loads.

.38 SPECIAL - LYMAN BULLETS



#358212

146 gr. (Linotype) 1.515" OAL

| POWDER | Sugg. | Velocity fps | Pressure C.U.P. | Max. | Velocity fps | Pressure C.U.P. |
|----------|--------------------|-----------------|--------------------|----------------|-----------------|--------------------|
| | Starting Grains | | | Load Grains | | |
| 700X | 2.8 | 674 | 9,400 | 4.0 | 881 | 15,900 |
| SR-7625 | 3.5 | 594 | 6,900 | 5.0 | 899 | 16,100 |
| Bullseye | 2.7 | 612 | 8,000 | 4.3 | 906 | 15,800 |
| Red Dot | 2.8 | 650 | 8,800 | 4.3 | 917 | 16,400 |
| Unique | 3.7 | 652 | 9,000 | 5.4 | 928 | 15,900 |
| 231 | 3.2 | 617 | 7,900 | 5.0 | 930 | 16,700 |
| HP38 | 3.0 | 654 | 9,300 | 4.4 | 900 | 16,500 |



#35863

148 gr., (Linotype) 1.152" OAL

| POWDER | Sugg. | Velocity fps | Pressure C.U.P. | Max. | Velocity fps | Pressure C.U.P. |
|----------|--------------------|-----------------|--------------------|----------------|-----------------|--------------------|
| | Starting Grains | | | Load Grains | | |
| 700X | 2.0 | 584 | 6,900 | 3.5 | 961 | 16,300 |
| SR-7625 | 2.8 | 674 | 8,700 | 4.0 | 928 | 15,800 |
| Bullseye | 2.4 | 664 | 8,400 | 3.8 | 950 | 16,100 |
| Red Dot | 2.5 | 678 | 8,700 | 3.7 | 945 | 15,900 |
| Unique | 3.1 | 670 | 8,100 | 4.6 | 994 | 16,800 |
| 231 | 2.5 | 600 | 6,600 | 4.1 | 957 | 16,000 |
| HP38 | 2.7 | 750 | 10,400 | 3.9 | 972 | 16,400 |
| HS-5 | 4.0 | 778 | 10,900 | 5.8 | 981 | 16,400 |
| AL-5 | 3.3 | 588 | 6,700 | 5.4 | 988 | 15,700 |

Note: Loads shown in shaded panels are maximum.

* Designates potentially most accurate load.

.38 SPECIAL - LYMAN BULLETS



#35891

148 gr., (Linotype) 1.317" OAL

| POWDER | Sugg. Starting Grains | Velocity fps | Pressure C.U.P. | Max. Load Grains | Velocity fps | Pressure C.U.P. |
|----------|-----------------------|--------------|-----------------|------------------|--------------|-----------------|
| 700X | 2.0 | 512 | 6,000 | 3.6 | 889 | 15,900 |
| SR-7625 | 2.8 | 517 | 5,800 | 4.7 | 958 | 16,500 |
| Bullseye | 2.8 | 568 | 8,900 | 4.4 | 953 | 16,200 |
| Red Dot | 2.7 | 524 | 7,900 | 4.1 | 939 | 16,800 |
| Unique | 3.4 | 660 | 8,500 | 5.0 | 948 | 16,100 |
| 231 | 2.8 | 626 | 7,900 | *4.6 | 914 | 15,600 |
| HP38 | 2.0 | 635 | 8,700 | 4.1 | 911 | 16,700 |
| HS-5 | 4.2 | 657 | 8,800 | 6.4 | 965 | 16,400 |
| AL-5 | 3.3 | 647 | 8,300 | 6.7 | 986 | 16,800 |

Note: Loads shown in shaded panels are maximum.
* Designates potentially most accurate load.

.38 SPECIAL - LYMAN BULLETS



#358156

155 gr. (Linotype) 1.460" OAL

| POWDER | Sugg. Starting Grains | Velocity fps | Pressure C.U.P. | Max. Load Grains | Velocity fps | Pressure C.U.P. |
|----------|-----------------------|--------------|-----------------|------------------|--------------|-----------------|
| PB | 3.0 | 584 | 8,700 | 4.2 | 825 | 16,200 |
| SR-4756 | 4.2 | 630 | 9,500 | 5.5 | 898 | 16,700 |
| Bullseye | 2.8 | 638 | 10,000 | 4.0 | 858 | 16,000 |
| | | | | (+P)4.4 | 915 | 18,100 |
| Unique | 3.4 | 601 | 8,900 | 5.1 | 895 | 16,100 |
| | | | | (+P)5.4 | 954 | 18,000 |
| Blue Dot | 6.0 | 686 | 10,400 | 7.2 | 867 | 15,700 |
| 231 | 3.5 | 680 | 11,100 | 4.7 | 885 | 16,800 |
| | | | | (+P)5.0 | 934 | 18,000 |
| HS-6 | 4.4 | 564 | 8,000 | 6.7 | 894 | 16,600 |
| HP-38 | 2.8 | 642 | 10,200 | 3.9 | 854 | 16,300 |
| | | | | (+P)4.1 | 882 | 17,800 |

Note: Loads shown in shaded panels are maximum.

(+P) Designates higher pressure loads.

.38 SPECIAL - LYMAN BULLETS



#356311

158 gr. (Linotype) 1.550" OAL

| POWDER | Sugg. Starting Grains | Velocity fps | Pressure C.U.P. | Max. Load Grains | Velocity fps | Pressure C.U.P. |
|----------|-----------------------|--------------|-----------------|------------------|--------------|-----------------|
| PB | 3.0 | 604 | 7,900 | 4.5 | 871 | 16,100 |
| SR-4756 | 4.2 | 620 | 8,700 | 5.5 | 874 | 16,000 |
| Bullseye | 2.8 | 656 | 10,000 | 4.2 | 880 | 16,200 |
| | | | | (+P)4.5 | 931 | 18,200 |
| Unique | 3.4 | 611 | 8,300 | 5.1 | 896 | 16,400 |
| | | | | (+P)5.4 | 946 | 18,000 |
| Blue Dot | 5.9 | 673 | 9,100 | 7.8 | 919 | 16,400 |
| 231 | 3.5 | 675 | 9,600 | 4.9 | 906 | 16,800 |
| | | | | (+P)5.2 | 956 | 18,500 |
| HS-6 | 4.5 | 610 | 8,200 | 6.7 | 901 | 16,200 |
| HP-38 | 2.6 | 621 | 8,800 | 4.3 | 902 | 16,900 |
| | | | | (+P)4.5 | 944 | 18,400 |

Note: Loads shown in shaded panels are maximum.
(+P) Designates higher pressure loads.

.38 SPECIAL - LYMAN BULLETS



#357446

162 gr. (Linotype) 1.457" OAL

| POWDER | Sugg. Starting Grains | Velocity fps | Pressure C.U.P. | Max. Load Grains | Velocity fps | Pressure C.U.P. |
|----------|-----------------------------|-----------------|--------------------|------------------------|-----------------|--------------------|
| PB | 3.4 | 646 | 9,500 | 4.6 | 877 | 16,300 |
| SR-4756 | 4.6 | 694 | 10,400 | 5.8 | 921 | 16,800 |
| Bullseye | 3.0 | 680 | 10,100 | 4.2 | 889 | 16,900 |
| Unique | 3.5 | 639 | 8,900 | 5.2 | 914 | 16,200 |
| Blue Dot | 5.8 | 675 | 9,500 | 7.7 | 948 | 16,500 |
| 231 | 3.4 | 702 | 10,400 | 4.6 | 896 | 16,000 |
| HP-6 | 5.1 | 690 | 9,600 | 6.7 | 922 | 16,100 |



#358429

168 gr. (Linotype) 1.537" OAL

| POWDER | Sugg. Starting Grains | Velocity fps | Pressure C.U.P. | Max. Load Grains | Velocity fps | Pressure C.U.P. |
|----------|-----------------------------|-----------------|--------------------|------------------------|-----------------|--------------------|
| SR-7625 | 3.4 | 621 | 9,700 | 4.6 | 821 | 16,300 |
| SR-4756 | 4.2 | 645 | 10,000 | 5.4 | 836 | 16,400 |
| Bullseye | 2.6 | 597 | 9,300 | 4.2 | 850 | 16,800 |
| Unique | 3.8 | 673 | 11,000 | 5.0 | 860 | 16,700 |
| Blue Dot | 5.5 | 647 | 10,000 | 7.3 | 869 | 16,500 |
| 231 | 3.0 | 599 | 9,300 | 4.6 | 855 | 16,900 |
| HP-6 | 5.0 | 677 | 11,000 | 6.4 | 856 | 16,800 |
| AA 5 | 4.3 | 755 | 11,500 | 5.1 | 894 | 16,100 |
| Clays | 2.3 | 722 | 11,500 | 2.9 | 824 | 15,900 |

Note: Loads shown in shaded panels are maximum.

RCBS®

RCBS®

RCBS®

RCBS®

THE RCBS® LIFETIME GUARANTEE.

RCBS.

**EVERYTHING
WE MAKE
IS GUARANTEED
FOR LIFE
OR FOREVER:
WHICHEVER
COMES FIRST.**

*If your RCBS equipment breaks or
doesn't work, we'll fix it or replace it. Free.
No time limit. No questions asked.*

GUARANTEE

.38 SPECIAL - RCBS BULLETS

Gun: S&W Model 14
 Barrel: 6"
 Twist: 1-18"
 Cases: Speer
 Primers: CCI 500, *550

Wt. 140 GR.
 Dia. .358"
 Lube: Pistol

38-148-WC



| POWDER | WT. IN GRAINS | MUZ VEL | POWDER | WT. IN GRAINS | MUZ VEL |
|---------------|---------------|---------|-----------------|---------------|---------|
| Unique | 5.2 | 999 | SR | 4.2 | 900 |
| | 4.7 | 894 | 7625 | 3.7 | 797 |
| 231 | 4.5 | 951 | 700X | 4.0 | 949 |
| | 4.0 | 853 | | 3.5 | 833 |
| HP38 | 4.4 | 959 | Bullseye | 4.0 | 904 |
| | 3.9 | 852 | | 3.5 | 788 |

Wt. 148 GR.
 Dia. .358"
 Lube: Pistol

38-148-WC



| POWDER | WT. IN GRAINS | MUZ VEL | POWDER | WT. IN GRAINS | MUZ VEL |
|-----------------|---------------|---------|----------------|---------------|---------|
| HS5 | 5.0 | 770 | Red Dot | 4.3 | 960 |
| | 4.5 | 696 | | 3.8 | 843 |
| Bullseye | 4.5 | 960 | SR | 4.2 | 903 |
| | 4.0 | 843 | 7625 | 3.7 | 805 |
| 231 | 4.5 | 946 | 700X | 4.0 | 934 |
| | 4.0 | 848 | | 3.5 | 821 |

Wt. 150 GR.
 Dia. .358"
 Lube: Pistol

38-150-SWC



| POWDER | WT. IN GRAINS | MUZ VEL | POWDER | WT. IN GRAINS | MUZ VEL |
|-------------|---------------|---------|-----------------|---------------|---------|
| IMR | *12.6 | 1002 | 231 | 5.0 | 980 |
| 4227 | *11.6 | 914 | | 4.5 | 887 |
| H110 | *10.7 | 953 | Bullseye | 4.5 | 925 |
| | * 9.7 | 857 | | 4.0 | 829 |
| 2400 | *10.2 | 1022 | 700X | 4.0 | 916 |
| | * 9.2 | 918 | | 3.5 | 795 |

.38 SPECIAL - RCBS BULLETS

Wt. 159 GR.

Dia. .358"

Lube: Pistol

38-158-SWC



| POWDER | WT. IN GRAINS | MUZ VEL | POWDER | WT. IN GRAINS | MUZ VEL |
|-------------|----------------|-------------|----------|---------------|------------|
| IMR 4227 | *12.0 *11.0 | 992 874 | HP38 | 4.3 3.8 | 847 783 |
| 2400 | *10.0 * 9.0 | 1020 926 | 231 | 4.2 3.7 | 810 744 |
| HS5 | 5.7 5.2 | 880 803 | Bullseye | 4.0 3.5 | 859 792 |
| SR 4756 | 4.6 4.1 | 803 738 | Red Dot | 4.0 3.5 | 858 792 |

*DENOTES USE OF CCI #250 MAGNUM PRIMER

Wt. 159 GR.

Dia. .358"

Lube: Pistol

38-158-RN



| POWDER | WT. IN GRAINS | MUZ VEL | POWDER | WT. IN GRAINS | MUZ VEL |
|------------|---------------|------------|----------|---------------|------------|
| HS5 | 5.7 5.2 | 889 793 | Bullseye | 4.0 3.5 | 902 815 |
| SR 4756 | 4.6 4.1 | 819 738 | Red Dot | 4.0 3.5 | 891 802 |
| HP38 | 4.3 3.8 | 879 791 | 700X | 3.8 3.3 | 894 811 |
| 231 | 4.2 3.7 | 848 783 | Trap 100 | 3.3 2.8 | 778 702 |

Wt. 175 GR.

Dia. .358"

Lube: Pistol

38-175-RN



| POWDER | WT. IN GRAINS | MUZ VEL | POWDER | WT. IN GRAINS | MUZ VEL |
|----------|---------------|------------|------------|---------------|------------|
| H110 | *9.7 *9.2 | 829 783 | SR 4756 | 5.0 4.5 | 915 827 |
| 2400 | *9.3 *8.8 | 945 881 | 231 | 4.2 3.7 | 844 752 |
| Blue Dot | *6.5 *6.0 | 810 759 | Bullseye | 4.0 3.5 | 858 757 |

*DENOTES USE OF CCI #560 MAGNUM PRIMER

Praise The Lord



With the Superior Performance of Hodgdon Powders

Superior accuracy can be achieved through reloading with reliable, consistently performing powder. To achieve this level of consistency, the experts at Hodgdon's select only the finest raw materials and give special attention to blending. Rigorous testing of *each* batch of powder further attests to Hodgdon's commitment to quality.

For over 45 years, Hodgdon Powder has been a performance leader among shooters. This explains why more winning shooters competing in benchrest matches use Hodgdon Powder.

Hodgdon encourages every shooter to enjoy the advantages and economy of reloading with the superior performance of Hodgdon Powders. For more information on reloading & Hodgdon Powders, write:

HODGDON POWDER COMPANY, INC.

P.O. Box 2932, Dept. AB

Shawnee Mission, KS 66201

HODGDON'S INDUSTRY INSIDERS



Russ Rolandson
Sales, Speer Bullets
300 Win. Mag. Caliber
165 gr. Speer Grand Slam
72 Gr. Hodgdon H4350 Powder

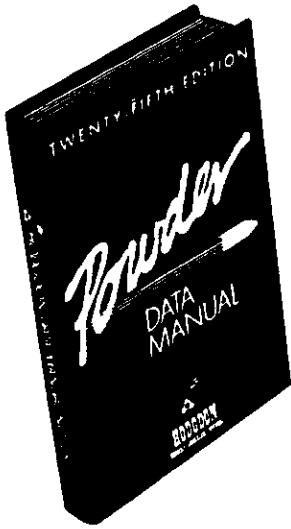

**Required
Reading
for
All Reloaders!**
*The
Hodgdon
Data Manual*

The Hodgdon Data Manual is the most extensive reloading manual produced by a powder company. **Over 500 pages** of rifle, pistol and shotgun data and includes articles by many well known writers.

- Includes data on Hodgdon, Hercules, Winchester and IMR powders for rifle calibers.
- Complete rifle, lead bullet, shotshell, pistol, military and silhouette data included.
- Complete Pyrodex® section of data and loading information for muzzleloading guns and early cartridge firearms.

THE FAVORITE OF HANDLOADERS SINCE 1946

The most current edition of the Hodgdon Data Manual is available from your local dealer or may be ordered directly from:

Hodgdon Powder Company, Inc.

P.O. Box 2932, Dept.. AB
Shawnee Mission, KS 66201
(913) 362-9455

**HODGDON
POWDER CO.**

38 SPECIAL

The 38 Smith & Wesson Special appeared as a commercial cartridge in 1902 and has been used mostly as a self defense/target cartridge for the better part of 90 years. It doesn't really matter what bullet design or weight is used with any reasonable powder charge, the 38 Special responds with respectable accuracy. A separate section is provided for +P loads for use in handguns that are approved for the higher pressures. As a rule, however, the vast majority of .357 inch jacketed handgun bullets are designed for higher pressures and velocities produced by the 357 Magnum, and they may not expand when fired at lower velocities in standard or +P loads in the 38 Special.

• • •

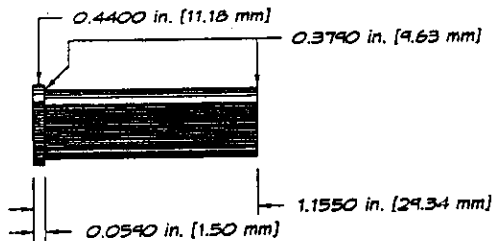

WINCHESTER
7.7"

WINCHESTER SP

1:18.75"
1.145"

.38 SPECIAL - HODGDON POWDERS

| Powder | Starting Loads | | | Maximum Loads | | |
|--------|----------------|------|----------|---------------|------|----------|
| | Grs. | Vel. | Pressure | Grs. | Vel. | Pressure |

38 SPECIAL

Case: WINCHESTER Twist: 1:18.75"
 Barrel: 7.7" Trim: 1.145" Primer: WINCHESTER SP

Bullet: 110 GR. HDY XTP Dia.: .357" COL: 1.455"

| | | | | | | |
|-----------|-----|------|------------|-----|------|------------|
| HS-6 | 7.0 | 1071 | 14,500 CUP | 7.8 | 1178 | 17,000 CUP |
| UNIVERSAL | 5.0 | 968 | 11,800 CUP | 5.6 | 1143 | 16,700 CUP |
| HP-38 | 4.6 | 948 | 12,600 CUP | 5.5 | 1096 | 16,300 CUP |
| TITEGROUP | 4.3 | 1011 | 12,100 CUP | 4.8 | 1109 | 16,000 CUP |
| CLAYS | 4.0 | 1002 | 14,400 CUP | 4.2 | 1073 | 17,000 CUP |

Bullet: 125 GR. CAST LRNFP Dia.: .358" COL: 1.445"

| | | | | | | |
|-----------|-----|-----|------------|-----|------|------------|
| UNIVERSAL | 4.3 | 872 | 8,700 CUP | 4.7 | 1036 | 16,800 CUP |
| HP-38 | 3.8 | 876 | 10,300 CUP | 4.8 | 1071 | 16,900 CUP |
| TITEGROUP | 3.2 | 856 | 8,400 CUP | 3.8 | 985 | 12,000 CUP |
| CLAYS | 2.5 | 810 | 8,400 CUP | 3.5 | 978 | 16,900 CUP |

Bullet: 125 GR. HDY XTP Dia.: .357" COL: 1.455"

| | | | | | | |
|-----------|-----|-----|------------|-----|------|------------|
| HS-6 | 6.5 | 931 | 13,100 CUP | 7.2 | 1048 | 16,600 CUP |
| UNIVERSAL | 4.7 | 918 | 12,600 CUP | 5.2 | 1019 | 17,000 CUP |
| HP-38 | 4.3 | 826 | 13,300 CUP | 4.9 | 934 | 16,300 CUP |
| TITEGROUP | 4.3 | 953 | 12,800 CUP | 4.6 | 1010 | 15,600 CUP |
| CLAYS | 3.5 | 843 | 12,400 CUP | 3.9 | 937 | 16,100 CUP |

Bullet: 135 GR. CAST LRNFP Dia.: .358" COL: 1.418"

| | | | | | | |
|-----------|-----|-----|------------|-----|------|------------|
| UNIVERSAL | 4.1 | 924 | 13,400 CUP | 4.6 | 1025 | 16,900 CUP |
| HP-38 | 3.7 | 872 | 12,500 CUP | 4.7 | 1024 | 17,000 CUP |
| TITEGROUP | 3.1 | 824 | 9,600 CUP | 3.6 | 927 | 12,900 CUP |
| CLAYS | 2.6 | 767 | 11,400 CUP | 3.3 | 910 | 16,200 CUP |

Bullet: 140 GR. HDY XTP Dia.: .357" COL: 1.455"

| | | | | | | |
|-----------|-----|-----|------------|-----|-----|------------|
| HS-6 | 5.8 | 808 | 11,000 CUP | 6.5 | 933 | 16,000 CUP |
| UNIVERSAL | 4.3 | 832 | 12,400 CUP | 4.8 | 939 | 15,400 CUP |
| HP-38 | 4.2 | 809 | 13,900 CUP | 4.6 | 861 | 15,800 CUP |
| TITEGROUP | 3.9 | 864 | 13,100 CUP | 4.2 | 919 | 15,800 CUP |
| CLAYS | 3.0 | 703 | 13,400 CUP | 3.7 | 869 | 16,700 CUP |

NEVER EXCEED MAXIMUM LOADS.

.38 SPECIAL - HODGDON POWDERS

| Powder | Starting Loads | | | Maximum Loads | | |
|--------|----------------|------|----------|---------------|------|----------|
| | Grs. | Vel. | Pressure | Grs. | Vel. | Pressure |

| | | | | | | | |
|--------------------------------|-----|-----|------------|--------------------|-----|--------------------|--|
| Bullet: 146 GR. SPR JHP | | | | Dia.: .357" | | COL: 1.370" | |
| H4227 | 9.6 | 908 | 12,600 CUP | 10.7 | 979 | 15,700 CUP | |
| HS-6 | 5.6 | 808 | 11,700 CUP | 6.3 | 969 | 16,100 CUP | |
| UNIVERSAL | 4.0 | 788 | 11,100 CUP | 4.5 | 933 | 16,100 CUP | |
| HP-38 | 4.0 | 773 | 12,700 CUP | 4.5 | 876 | 15,500 CUP | |
| TITEGROUP | 3.5 | 808 | 12,800 CUP | 4.0 | 914 | 16,000 CUP | |

| | | | | | | | |
|----------------------------------|-----|-----|------------|--------------------|-----|------------|--|
| Bullet: 148 GR. HDY LHBWC | | | | Dia.: .358" | | | |
| COL: 1.160" | | | | | | | |
| HS-6 | 4.5 | 816 | 9,200 CUP | 5.2 | 943 | 14,300 CUP | |
| UNIVERSAL | 2.9 | 709 | 7,400 CUP | 3.8 | 940 | 15,600 CUP | |
| HP-38 | 3.5 | 869 | 14,200 CUP | 4.0 | 956 | 15,900 CUP | |
| TITEGROUP | 2.7 | 771 | 7,700 CUP | 3.3 | 908 | 11,800 CUP | |
| CLAYS | 2.3 | 784 | 10,900 CUP | 2.5 | 836 | 13,200 CUP | |

| | | | | | | | |
|----------------------------------|-----|-----|------------|--------------------|------|------------|--|
| Bullet: 158 GR. CAST LSWC | | | | Dia.: .358" | | | |
| COL: 1.475" | | | | | | | |
| H4227 | 9.0 | 887 | 12,100 CUP | 10.0 | 983 | 15,700 CUP | |
| HS-6 | 5.7 | 928 | 13,700 CUP | 6.3 | 1010 | 16,200 CUP | |
| UNIVERSAL | 3.5 | 756 | 9,600 CUP | 4.5 | 974 | 16,700 CUP | |
| HP-38 | 3.1 | 782 | 11,900 CUP | 3.7 | 834 | 14,600 CUP | |
| TITEGROUP | 3.2 | 815 | 11,500 CUP | 3.8 | 920 | 15,400 CUP | |
| CLAYS | 2.8 | 812 | 12,900 CUP | 3.1 | 871 | 15,100 CUP | |

| | | | | | | | |
|--------------------------------|-----|-----|------------|--------------------|-----|--------------------|--|
| Bullet: 158 GR. HDY XTP | | | | Dia.: .357" | | COL: 1.455" | |
| H4227 | 9.0 | 769 | 12,400 CUP | 10.0 | 864 | 15,500 CUP | |
| HS-6 | 5.6 | 761 | 13,400 CUP | 6.2 | 862 | 16,300 CUP | |
| UNIVERSAL | 4.0 | 678 | 12,600 CUP | 4.4 | 778 | 16,200 CUP | |
| HP-38 | 3.8 | 661 | 12,600 CUP | 4.3 | 779 | 15,900 CUP | |
| TITEGROUP | 3.5 | 704 | 12,400 CUP | 3.9 | 798 | 15,900 CUP | |
| CLAYS | 3.0 | 633 | 13,400 CUP | 3.1 | 721 | 16,600 CUP | |

| | | | | | | | |
|--------------------------------|-----|-----|------------|--------------------|-----|--------------------|--|
| Bullet: 170 GR. SIE JHC | | | | Dia.: .357" | | COL: 1.450" | |
| H4227 | 8.8 | 762 | 12,900 CUP | 9.8 | 888 | 15,900 CUP | |
| HS-6 | 5.3 | 710 | 12,200 CUP | 5.9 | 832 | 16,100 CUP | |
| UNIVERSAL | 3.8 | 744 | 14,100 CUP | 4.2 | 823 | 16,100 CUP | |
| HP-38 | 3.8 | 683 | 12,200 CUP | 4.1 | 752 | 15,800 CUP | |
| TITEGROUP | 3.0 | 635 | 11,100 CUP | 3.6 | 764 | 16,000 CUP | |

NEVER EXCEED MAXIMUM LOADS.

.38 SPECIAL - HODGDON POWDERS

| <i>Powder</i> | <i>Starting Loads</i> | | | <i>Maximum Loads</i> | | |
|--|-----------------------|-------------|-----------------|----------------------|-------------|-----------------|
| | <i>Grs.</i> | <i>Vel.</i> | <i>Pressure</i> | <i>Grs.</i> | <i>Vel.</i> | <i>Pressure</i> |
| Bullet: 140 GR. HDY XTP Dia.: .357" COL: 1.455" | | | | | | |
| H4227 | | | | 12.4 | 1121 | 19,400 CUP |
| HS-6 | | | | 7.0 | 992 | 18,300 CUP |
| UNIVERSAL | | | | 5.1 | 1022 | 19,100 CUP |
| HP-38 | | | | 4.9 | 892 | 18,600 CUP |
| TITEGROUP | | | | 4.6 | 984 | 19,300 CUP |
| Bullet: 146 GR. SPR JHP Dia.: .357" COL: 1.370" | | | | | | |
| H4227 | | | | 12.0 | 1085 | 18,400 CUP |
| HS-6 | | | | 6.7 | 1035 | 18,400 CUP |
| UNIVERSAL | | | | 4.7 | 987 | 18,100 CUP |
| HP-38 | | | | 4.9 | 975 | 17,700 CUP |
| TITEGROUP | | | | 4.4 | 981 | 19,300 CUP |
| Bullet: 158 GR. HDY XTP Dia.: .357" COL: 1.455" | | | | | | |
| H4227 | | | | 11.0 | 964 | 17,600 CUP |
| HS-6 | | | | 6.6 | 926 | 18,700 CUP |
| UNIVERSAL | | | | 4.7 | 837 | 19,200 CUP |
| HP-38 | | | | 4.6 | 807 | 18,100 CUP |
| TITEGROUP | | | | 4.3 | 905 | 19,300 CUP |
| Bullet: 170 GR. SIE JHC Dia.: .357" COL: 1.450" | | | | | | |
| H4227 | | | | 10.6 | 950 | 17,600 CUP |
| HS-6 | | | | 6.3 | 897 | 18,600 CUP |
| UNIVERSAL | | | | 4.3 | 847 | 18,600 CUP |
| HP-38 | | | | 4.4 | 819 | 18,100 CUP |
| TITEGROUP | | | | 4.0 | 846 | 19,000 CUP |

NEVER EXCEED MAXIMUM LOADS.

.38 SPECIAL - ACCURATE ARMS POWDERS

Introduction

There has been a re-evaluation of the criteria for selecting data for inclusion. This means there will be some disagreement with previous data. The data in this guide takes precedence over all prior publications. *Previous editions of this loading guide should be discarded.*

For instance, we left out load combinations that were 'position sensitive'. This is what occurs when the load density is low. Velocity with the powder at the bullet is different from the velocity with the powder at the primer. More of these were noted with the ball propellants than with the extruded propellants.

In light of the growth of IPSC shooting, 38 Super Auto loads that make the 'major' classification (bullet weight x velocity = 175,000) are identified. While we have tested many combinations of components in 9mm Luger to attempt to meet 'major' requirements, we have not been able to find a load that makes the power floor for 'major' without exceeding SAAMI pressure recommendations. And while we were able to find loads for 38 Super Auto, they were not with lighter bullets. Turn to the data section for specific details.

In the charge tables, the 'START' charge listed for each load is our suggested beginning point with the components listed. There is the possibility that changing the named components could cause the maximum charge to be excessive, thus a reduction of the charge would be necessary. Some batches of military brass may require reducing the maximum charge by 8-12% to keep chamber pressure in line.

If you find signs of excessive pressure while using loads in this loading guide, STOP TESTING and verify all data and loading procedures. If they seem to be in order, check with our lab facility before proceeding.

Charge weights were obtained using industry standard pressure barrels. When time permitted, off-the-shelf weapons were used to obtain velocity figures. The guns used are noted.

In reloading, the prime concern should always be SAFETY. **Always** wear eye protection when reloading, even when working with the 'non-volatile' components. **Always** keep the reloading area clean. **Never** have more than one propellant within easy reach at any given time. Avoid having similar looking bullets of different weights on the bench at the same time. Read the safety notes before loading.

We have not found magnum primers to offer any particular advantage with our handgun powders. But, there are some rifle cartridges where they were used.

Handgun loads using the slower powders (No.7, No.9, and 1680) require heavy crimp and high bullet pull to insure consistency - particularly with cast bullet loads or in extremely cold weather. Be sure your dies are capable of this, otherwise the consistency of the load will be affected.

In the text, bullet weights for cast bullets - identified by (L) are actual weights, not the nominal weights.

.38 SPECIAL - ACCURATE POWDERS

.38 SMITH & WESSON SPECIAL

The .38 S&W Special continues to be the most popular handgun cartridge in the U.S. It is very accurate and is widely used for competitive shooting.

Also known as the .38 Colt Special, or more generally as the .38 Special, it was introduced by Smith & Wesson in 1902 for their military and police model revolver.

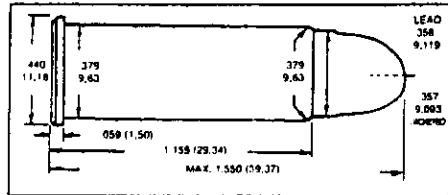

This is an excellent cartridge for the novice handgunner due to its inherent accuracy and low recoil. The .38 Special is also a popular sporting cartridge. Its hunting use should be restricted to small game at close range.

The SAAMI Maximum Average Pressure for the .38 S&W Special is 17,000 P.S.I.

.38 SMITH & WESSON SPECIAL

| | | | |
|---------------|----------|-------------|--------------------|
| Gun | S&W K-38 | Max Length | 1.155" |
| Barrel Length | 8-3/8" | Trim Length | 1.135" |
| Primer | CCI 500 | OAL Max | 1.550" |
| Case | HDY | OAL Min | 1.145" (Wadcutter) |

| Bullet | START LOADS | | | MAXIMUM LOADS | | | P.S.I. | Cartridge Length | Comment |
|--------------|-------------|--------|------|---------------|--------|------|--------|------------------|----------|
| | Powder | Grains | Vel. | Powder | Grains | Vel. | | | |
| 148 (L) DEWC | N100 | 2.4 | 759 | N100 | 2.7 | 863 | 15,300 | 1.252" | CP |
| | S1000 | 2.4 | 730 | S1000 | 2.7 | 830 | 15,100 | | |
| | No.2 | 3.2 | 748 | No.2 | 3.5 | 850 | 16,000 | | |
| | No.5 | 4.5 | 803 | No.5 | 5.0 | 912 | 16,500 | | |
| 148 (L) HBWC | N100 | 2.5 | 776 | N100 | 2.8 | 882 | 17,500 | 1.152" | HDY |
| | S1000 | 2.5 | 736 | S1000 | 2.8 | 837 | 15,800 | | |
| | No.2 | 2.6 | 634 | No.2 | 2.9 | 720 | 15,500 | | |
| | No.5 | 3.6 | 710 | No.5 | 4.0 | 807 | 16,200 | | |
| 158 (L) SWC | N100 | 2.9 | 786 | N100 | 3.3 | 894 | 16,600 | 1.481" | Bull-X |
| | S1000 | 3.0 | 754 | S1000 | 3.4 | 857 | 14,900 | | |
| | No.2 | 3.6 | 764 | No.2 | 4.0 | 868 | 14,100 | | |
| | No.5 | 5.3 | 827 | No.5 | 5.9 | 940 | 16,100 | | |
| 173 (L) SWC | No.2 | 3.6 | 721 | No.2 | 4.0 | 819 | 16,300 | 1.515" | LY358429 |
| | No.5 | 4.9 | 766 | No.5 | 5.4 | 870 | 16,500 | | |
| 195 (L) RN | No.2 | 3.2 | 706 | No.2 | 3.5 | 803 | 16,900 | 1.550" | LY358430 |
| | No.5 | 4.5 | 740 | No.5 | 5.0 | 841 | 14,900 | | |
| | No.7 | 5.9 | 786 | No.7 | 6.5 | 894 | 15,200 | | |

.38 SPECIAL - ACCURATE POWDERS

.38 SMITH & WESSON SPECIAL (continued)

| Bullet | START LOADS | | | MAXIMUM LOADS | | | P.S.I. | Cartridge Length | Comment |
|----------------|-------------|--------|------|---------------|--------|------|--------|------------------|---------|
| | Powder | Grains | Vel | Powder | Grains | Vel | | | |
| HDY 110 XTP | N100 | 3.9 | 1014 | N100 | 4.4 | 1153 | 15,900 | 1.435* | |
| | S1000 | 3.9 | 962 | S1000 | 4.4 | 1094 | 16,800 | | |
| | No.2 | 5.0 | 953 | No.2 | 5.6 | 1083 | 16,800 | | |
| | No.5 | 6.6 | 959 | No.5 | 7.3 | 1090 | 16,600 | | |
| SPR 125 JHP | N100 | 3.7 | 907 | N100 | 4.1 | 1031 | 14,800 | 1.445* | |
| | S1000 | 3.7 | 888 | S1000 | 4.1 | 1010 | 15,700 | | |
| | No.2 | 4.8 | 871 | No.2 | 5.3 | 990 | 16,800 | | |
| | No.5 | 6.1 | 757 | No.5 | 6.8 | 860 | 16,300 | | |
| RAN 125 FP | No.2 | 4.2 | 953 | No.2 | 4.7 | 1083 | 17,000 | 1.430* | |
| | No.5 | 6.5 | 1030 | No.5 | 7.2 | 1171 | 17,000 | | |
| SPR 140 JHP | N100 | 3.5 | 821 | N100 | 3.9 | 933 | 16,900 | 1.445* | |
| | S1000 | 3.5 | 782 | S1000 | 3.9 | 889 | 16,600 | | |
| | No.2 | 4.2 | 781 | No.2 | 4.7 | 888 | 16,700 | | |
| | No.5 | 5.8 | 757 | No.5 | 6.4 | 860 | 16,700 | | |
| RAN 148 DEWC | No.2 | 2.8 | 701 | No.2 | 3.1 | 797 | 16,500 | 1.175* | |
| | No.5 | 4.5 | 768 | No.5 | 5.0 | 873 | 15,900 | | |
| NOS 150 JHP | N100 | 3.3 | 791 | N100 | 3.7 | 899 | 15,800 | 1.450* | |
| | S1000 | 3.3 | 755 | S1000 | 3.7 | 859 | 16,200 | | |
| | No.2 | 4.2 | 751 | No.2 | 4.7 | 853 | 17,000 | | |
| | No.5 | 5.9 | 715 | No.5 | 6.5 | 813 | 16,600 | | |
| HDY 158 XTP | N100 | 2.9 | 691 | N100 | 3.2 | 786 | 14,400 | 1.445* | |
| | S1000 | 3.1 | 702 | S1000 | 3.4 | 798 | 15,900 | | |
| | No.2 | 3.8 | 665 | No.2 | 4.0 | 756 | 16,500 | | |
| | No.5 | 5.2 | 740 | No.5 | 5.8 | 841 | 16,500 | | |
| RAN 158 HP | No.2 | 3.4 | 739 | No.2 | 3.8 | 840 | 16,500 | 1.430* | |
| | No.5 | 5.4 | 830 | No.5 | 6.0 | 944 | 16,700 | | |
| RAN 158 RN | No.2 | 3.3 | 757 | No.2 | 3.7 | 861 | 16,600 | 1.430* | |
| | No.5 | 5.1 | 829 | No.5 | 5.7 | 943 | 16,900 | | |
| RAN 158 FN | No.2 | 3.3 | 727 | No.2 | 3.7 | 827 | 16,100 | 1.430* | |
| | No.5 | 5.3 | 836 | No.5 | 5.9 | 951 | 16,100 | | |
| Shot Capsules* | | | | | | | | | |
| 105 SC | No.5 | 5.4 | 910 | No.5 | 6.0 | 1035 | 16,500 | 1.500* | |

* Shot capsules using 105 grains of No.9 shot.

.38 SPECIAL +P LOADS - ACCURATE POWDERS

.38 SMITH & WESSON SPECIAL (+P)

This is a higher pressure loading of the popular .38 S&W Special. This was originally developed for use by law enforcement agencies.

The SAAMI Maximum Average Pressure for the .38 S&W Special +P is 18,500 P.S.I.

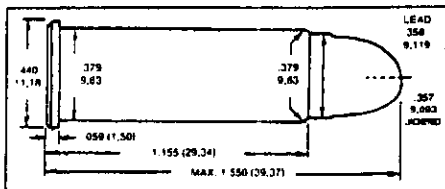

.38 SMITH & WESSON SPECIAL (+P)

| | | | |
|---------------|----------|-------------|--------|
| Gun | S&W K-38 | Max Length | 1.155* |
| Barrel Length | 8-3/8" | Trim Length | 1.135* |
| Primer | CCI 500 | OAL Max | 1.550* |
| Case | HDY | OAL Min | 1.400* |

| Bullet | START LOADS | | | MAXIMUM LOADS | | | P S I | Cartridge Length | Comment |
|-------------|-------------|--------|------|---------------|--------|------|--------|------------------|----------|
| | Powder | Grains | Vel. | Powder | Grains | Vel. | | | |
| 158 (L) SWC | No.2 | 4.2 | 879 | No.2 | 4.7 | 999 | 18,500 | 1.481" | Bull-X |
| | No.5 | 5.6 | 880 | No.5 | 6.2 | 1000 | 18,400 | | |
| 173 (L) SWC | No.2 | 3.8 | 748 | No.2 | 4.2 | 850 | 18,000 | 1.515" | LY358429 |
| | No.5 | 5.0 | 792 | No.5 | 5.6 | 900 | 17,900 | | |
| HDY 110 XTP | No.2 | 5.2 | 996 | No.2 | 5.8 | 1132 | 17,800 | 1.435" | |
| | No.5 | 6.8 | 1046 | No.5 | 7.5 | 1189 | 17,400 | | |
| SPR 125 JHP | No.2 | 5.0 | 899 | No.2 | 5.5 | 1022 | 17,700 | 1.445" | |
| | No.5 | 6.4 | 810 | No.5 | 7.1 | 920 | 17,300 | | |
| SPR 140 JHP | No.2 | 4.4 | 775 | No.2 | 4.9 | 881 | 18,300 | 1.445" | |
| | No.5 | 6.0 | 778 | No.5 | 6.7 | 884 | 17,800 | | |
| NOS 150 JHP | No.2 | 4.4 | 791 | No.2 | 4.9 | 899 | 17,600 | 1.450" | |
| | No.5 | 6.0 | 757 | No.5 | 6.7 | 860 | 18,200 | | |
| HDY 158 XTP | No.2 | 3.8 | 702 | No.2 | 4.2 | 798 | 17,800 | 1.445" | |
| | No.5 | 5.4 | 792 | No.5 | 6.0 | 900 | 18,500 | | |

.38 SPECIAL - ALLIANT POWDERS

ALLIANT CONTINUED

| POWDER | STARTING LOADS | | | MAXIMUM LOADS | | |
|---|----------------|------|----------|---------------|------|------------|
| | GRS. | VEL. | PRESSURE | GRS. | VEL. | PRESSURE |
| BULLET: 148 GR. LWC DIA. .358" C.O.L. 1.180" | | | | | | |
| BLUE DOT | | | | 5.3 | 810 | 13,600 PSI |
| HERCO | | | | 3.5 | 820 | 16,000 PSI |
| UNIQUE | | | | 3.3 | 815 | 15,300 PSI |
| GREEN DOT | | | | 2.9 | 800 | 15,900 PSI |
| RED DOT | | | | 2.5 | 750 | 15,500 PSI |
| BULLSEYE | | | | 2.8 | 815 | 15,900 PSI |
| BULLET: 148 GR. LWC (TGT) DIA. .358" C.O.L. 1.180" | | | | | | |
| UNIQUE | | | | 3.2 | 775 | 14,100 PSI |
| GREEN DOT | | | | 2.7 | 765 | 14,600 PSI |
| RED DOT | | | | 2.3 | 730 | 14,800 PSI |
| BULLSEYE | | | | 2.7 | 785 | 14,600 PSI |
| BULLET: 158 GR. LSWC DIA. .358" C.O.L. 1.420" | | | | | | |
| BLUE DOT | | | | 6.1 | 955 | 15,600 PSI |
| HERCO | | | | 4.5 | 930 | 15,800 PSI |
| UNIQUE | | | | 4.3 | 920 | 16,000 PSI |
| GREEN DOT | | | | 3.5 | 870 | 15,600 PSI |
| RED DOT | | | | 3.1 | 835 | 15,800 PSI |
| BULLSEYE | | | | 3.6 | 910 | 15,500 PSI |
| BULLET: 160 GR. JSP DIA. .357" C.O.L. 1.435" | | | | | | |
| BLUE DOT | | | | 6.2 | 845 | 15,800 PSI |
| HERCO | | | | 4.4 | 805 | 16,000 PSI |
| UNIQUE | | | | 4.2 | 800 | 15,600 PSI |
| BULLSEYE | | | | 3.5 | 805 | 15,600 PSI |
| BULLET: 200 GR. LRN DIA. .358" C.O.L. 1.540" | | | | | | |
| BLUE DOT | | | | 5.3 | 850 | 16,000 PSI |
| HERCO | | | | 3.8 | 785 | 15,500 PSI |
| UNIQUE | | | | 3.6 | 780 | 15,700 PSI |
| GREEN DOT | | | | 3.1 | 750 | 15,500 PSI |
| RED DOT | | | | 2.8 | 725 | 15,100 PSI |
| BULLSEYE | | | | 3.0 | 760 | 15,100 PSI |

NEVER EXCEED MAXIMUM LOADS.

.38 SPECIAL - IMR POWDERS

IMR

CASE: REMINGTON BARREL: 6" PRIMER: REMINGTON 1 1/2

STARTING LOADS MAXIMUM LOADS

POWDER GRS. VEL. PRESSURE GRS. VEL. PRESSURE

BULLET: 110 GR. HDY JHP DIA. .357" C.O.L. 1.450"

| | | | |
|-----------------|-----|------|------------|
| "HI-SKOR" 800-X | 7.2 | 1095 | 15,800 CUP |
| SR 4756 | 6.2 | 1040 | 15,600 CUP |
| SR 7625 | 5.5 | 1060 | 15,400 CUP |
| PB | 4.8 | 990 | 15,200 CUP |
| "HI-SKOR" 700-X | 4.2 | 970 | 15,400 CUP |

BULLET: 125 GR. REM JHP DIA. .357" C.O.L. 1.525"

| | | | |
|-----------------|-----|-----|------------|
| "HI-SKOR" 800-X | 6.9 | 980 | 15,500 CUP |
| SR 4756 | 6.1 | 925 | 15,900 CUP |
| SR 7625 | 5.3 | 935 | 15,900 CUP |
| PB | 4.6 | 865 | 15,500 CUP |
| "HI-SKOR" 700-X | 4.1 | 840 | 15,600 CUP |

BULLET: 140 GR. SPR JHP DIA. .357" C.O.L. 1.455"

| | | | |
|-----------------|-----|-----|------------|
| "HI-SKOR" 800-X | 6.0 | 830 | 15,700 CUP |
| SR 4756 | 5.6 | 765 | 16,000 CUP |
| SR 7625 | 4.6 | 780 | 15,800 CUP |
| PB | 4.2 | 735 | 15,700 CUP |
| "HI-SKOR" 700-X | 3.7 | 730 | 15,900 CUP |

BULLET: 146 GR. SPR JHP DIA. .357" C.O.L. 1.395"

| | | | |
|-----------------|-----|-----|------------|
| "HI-SKOR" 800-X | 5.8 | 805 | 15,400 CUP |
| SR 4756 | 5.2 | 840 | 15,600 CUP |
| SR 7625 | 4.2 | 740 | 15,600 CUP |
| PB | 3.9 | 725 | 15,700 CUP |
| "HI-SKOR" 700-X | 3.5 | 725 | 15,900 CUP |

BULLET: 148 GR. SPR LBBWC DIA. .358" C.O.L. 1.295"

| | | | | | | |
|-----------------|-----|-----|-----------|-----|-----|------------|
| "HI-SKOR" 800-X | 4.3 | 710 | 8,600 CUP | 5.5 | 905 | 15,900 CUP |
| SR 7625 | 3.2 | 715 | 8,200 CUP | 4.2 | 875 | 16,000 CUP |
| PB | 2.8 | 705 | 8,400 CUP | 3.8 | 855 | 15,800 CUP |
| "HI-SKOR" 700-X | 2.6 | 710 | 8,700 CUP | 3.5 | 850 | 16,000 CUP |

BULLET: 150 GR. SIE JHC DIA. .357" C.O.L. 1.445"

| | | | |
|-----------------|-----|-----|------------|
| "HI-SKOR" 800-X | 5.7 | 795 | 15,600 CUP |
| SR 4756 | 5.4 | 765 | 16,000 CUP |
| SR 7625 | 4.3 | 770 | 15,700 CUP |
| PB | 4.0 | 765 | 15,900 CUP |
| "HI-SKOR" 700-X | 3.5 | 755 | 15,900 CUP |

.38 SPECIAL - IMR POWDERS

IMR CONTINUED

| POWDER | STARTING LOADS | | | MAXIMUM LOADS | | | | |
|--------------------------------|----------------|------|-------------------|---------------|------|----------------------|--|--|
| | GRS. | VEL. | PRESSURE | GRS. | VEL. | PRESSURE | | |
| BULLET: 158 GR. HDY JFP | | | DIA. .357" | | | C.O.L. 1.465" | | |
| *HI-SKOR* 800-X | | | | 5.5 | 695 | 15,400 CUP | | |
| SR 4756 | | | | 5.2 | 705 | 15,300 CUP | | |
| SR 7625 | | | | 4.3 | 660 | 15,700 CUP | | |
| PB | | | | 3.9 | 620 | 16,000 CUP | | |
| *HI-SKOR* 700-X | | | | 3.4 | 585 | 15,300 CUP | | |
| BULLET: 158 GR. REM LRN | | | DIA. .358" | | | C.O.L. 1.520" | | |
| *HI-SKOR* 800-X | 4.8 | 750 | 11,500 CUP | 5.7 | 875 | 16,000 CUP | | |
| SR 7625 | 3.7 | 745 | 10,000 CUP | 4.3 | 790 | 15,200 CUP | | |
| PB | 3.4 | 745 | 11,700 CUP | 4.0 | 775 | 15,500 CUP | | |
| *HI-SKOR* 700-X | 3.0 | 740 | 11,700 CUP | 3.6 | 790 | 15,800 CUP | | |

NEVER EXCEED MAXIMUM LOADS.

.38 SPECIAL - IMR POWDERS

.38 SPECIAL + P

| IMR POWDER | | | | | | | | |
|--------------------------------|---|------|------|---------------|---------|------|--------|--------|
| STARTING LOADS | | | | MAXIMUM LOADS | | | | |
| BULLET | POWDER | GRS. | VEL. | CUP | POWDER | GRS. | VEL. | CUP |
| 110 GR. (J.H.P.) | NO REDUCTION IN CHARGES RECOMMENDED WITH THESE LOADS. THESE ARE HIGH VELOCITY LOADS ONLY. | | | | IMR4227 | 14.0 | 1290 | 17,900 |
| | | | | | SR4756 | 6.4 | 1169 | 18,000 |
| 125 GR. (J.H.P.) | | | | | IMR4227 | 13.5 | 1239 | 18,600 |
| | | | | | SR4756 | 6.0 | 1022 | 18,400 |
| 140 GR. (J.H.P.) | | | | | IMR4227 | 13.2 | 1166 | 19,400 |
| | | | | | SR4756 | 5.7 | 984 | 19,100 |
| 146- 150 GR. (J.H.P.) | | | | | IMR4227 | 12.8 | 1088 | 20,900 |
| | | | | | SR4756 | 5.5 | 944 | 19,600 |
| 158- 160 GR. (J.S.P.) | | | | IMR4227 | 12.2 | 1029 | 20,200 | |
| | | | | SR4756 | 5.2 | 880 | 19,900 | |
| 170 GR. (J.H.P.) | | | | IMR4227 | 11.3 | 959 | 19,400 | |
| 180 GR. (J.H.P.) | | | | IMR4227 | 10.7 | 844 | 21,000 | |

NEVER EXCEED MAXIMUM LOADS.

(Source: Hodgdon Reloading Manual # 26)

.38 SPECIAL - SCOT POWDERS

ROYAL SCOT

| <i>Powder Charge</i> | <i>Bullet Weight & Type</i> | <i>Muzzle Velocity</i> |
|----------------------|---------------------------------|------------------------|
| 4.6 grains | 110 grain Speer JHP | 1,032 fps |
| 4.1 grains | 125 grain Hornady JFP | 909 fps |
| 3.6 grains | 140 grain Hornady JHP | 763 fps |
| 2.7 grains | 148 grain Lead WC Target | 858 fps |
| 3.2 grains | 148 grain Lead WC | 933 fps |
| 3.4 grains | 158 grain Hornady JFP | 711 fps |
| 3.5 grains | 158 grain Lead SWC | 893 fps |

PEARL SCOT

| <i>Powder Charge</i> | <i>Bullet Weight & Type</i> | <i>Muzzle Velocity</i> |
|----------------------|---------------------------------|------------------------|
| 5.9 grains | 110 grain Speer JHP | 1,159 fps |
| 5.4 grains | 125 grain Hornady JFP | 1,021 fps |
| 4.7 grains | 140 grain Hornady JHP | 861 fps |
| 3.2 grains | 148 grain Lead WC Target | 829 fps |
| 3.6 grains | 148 grain Lead WC | 923 fps |
| 4.4 grains | 158 grain Hornady JFP | 797 fps |
| 4.2 grains | 158 grain Lead SWC | 903 fps |

SOLO 1000

| <i>Powder Charge</i> | <i>Bullet Weight & Type</i> | <i>Muzzle Velocity</i> |
|----------------------|---------------------------------|------------------------|
| 5.0 grains | 110 grain Speer JHP | 1,038 fps |
| 4.4 grains | 125 grain Hornady JFP | 965 fps |
| 3.9 grains | 140 grain Hornady JHP | 775 fps |
| 2.6 grains | 148 grain Lead WC Target | 829 fps |
| 3.2 grains | 148 grain Lead WC | 924 fps |
| 3.6 grains | 158 grain Hornady JFP | 702 fps |
| 3.6 grains | 158 grain Lead SWC | 884 fps |

.38 SPECIAL - SCOT POWDERS

SOLO 1250

| <i>Powder Charge</i> | <i>Bullet Weight & Type</i> | <i>Muzzle Velocity</i> |
|----------------------|---------------------------------|------------------------|
| 6.7 grains | 110 grain Speer JHP | 1,184 fps |
| 6.0 grains | 125 grain Hornady JFP | 1,035 fps |
| 5.3 grains | 140 grain Hornady JHP | 932 fps |
| 3.4 grains | 148 grain Lead WC Target | 797 fps |
| 4.0 grains | 148 grain Lead WC | 971 fps |
| 4.7 grains | 158 grain Hornady JFP | 775 fps |
| 4.6 grains | 158 grain Lead SWC | 919 fps |

SOLO 1500

| <i>Powder Charge</i> | <i>Bullet Weight & Type</i> | <i>Muzzle Velocity</i> |
|----------------------|---------------------------------|------------------------|
| 8.3 grains | 110 grain Speer JHP | 1,182 fps |
| 7.5 grains | 125 grain Hornady JFP | 992 fps |
| 6.7 grains | 140 grain Hornady JHP | 872 fps |
| 4.4 grains | 148 grain Lead WC Target | 794 fps |
| 5.5 grains | 148 grain Lead WC | 1,031 fps |
| 6.1 grains | 158 grain Hornady JFP | 805 fps |
| 6.1 grains | 158 grain Lead SWC | 972 fps |

= WARNING =

The Scot Powder Company makes no warranties or guarantees with respect to the safety or suitability of these products or the reloading information contained on these pages, either express or implied. Buyer and user assume any and all risk, responsibility and liability for any and all injury (including death), loss or damage arising from usage!

WINCHESTER Centerfire Rifle Components

When selecting reloading supplies, be sure to look for the following finest quality Winchester components.

Primers

WLR, #8-1/2 - 120, Large Rifle

WLRM, #8-1/2M - 120, Large Rifle Magnum

WSR, #6-1/2 - 116, Small Rifle

BALL POWDER Propellants

680 Powder, 1 Lb. Container

748 Powder, 1 and 8 Lb. Containers

760 Powder, 1 and 8 Lb. Containers

Unprimed Rifle

| | | | |
|--------|-------------------|-------|---------------|
| U218 | 218 Bee | U300H | 300 H&H Mag. |
| U22H | 22 Hornet | U300 | 300 Savage |
| U22250 | 22-250 Rem. | U307 | 307 Win. |
| U220S | 220 Swift | U308 | 308 Win. |
| U223R | 223 Rem. | U3220 | 32-20 Win. |
| U225 | 225 Win. | U338 | 338 Win. Mag. |
| U243 | 243 Win. | U348 | 348 Win. |
| U6MMR | 6mm Rem. | U356 | 356 Win. |
| U2520 | 25-20 Win. | U358 | 358 Win. |
| U2506 | 25-06 Rem. | U375H | 375 H&H Mag. |
| U257P | 257 Roberts + P | U375W | 375 Win. |
| U264 | 264 Win. Mag. | U4440 | 44-40 Win. |
| U270 | 270 Win. | U44M | 44 Rem. Mag. |
| U284 | 284 Win. | U4570 | 45-70 Govt. |
| U7MM | 7mm Mauser | U458 | 458 Win. Mag. |
| U3006 | 30-06 Springfield | | |
| U3040 | 30-40 Krag | | |
| U300WM | 300 Win. Mag. | | |



.38 SPECIAL - WINCHESTER POWDERS

.38 SPECIAL

| WINCHESTER POWDER | | | | | | | | | |
|--|--------|------|------|--------|---------------|------|------|--------|--|
| STARTING LOADS | | | | | MAXIMUM LOADS | | | | |
| BULLET | POWDER | GRS. | VEL. | CUP | POWDER | GRS. | VEL. | CUP | |
| 90 GR. (J.H.P.) | 231 | 4.8 | 1175 | 10,000 | 231 | 5.6 | 1194 | 15,400 | |
| 110 GR. (J.H.P.) | 231 | 4.6 | 998 | 12,400 | 231 | 5.2 | 1058 | 15,200 | |
| 125 GR. (J.H.P.) | 231 | 4.1 | 833 | 12,000 | 231 | 4.7 | 899 | 14,400 | |
| 140 GR. (J.H.P.) | 231 | 3.5 | 830 | 12,100 | 231 | 4.0 | 858 | 15,000 | |
| 146- 150 GR. (J.H.P.) | 231 | 3.4 | 820 | 13,100 | 231 | 3.9 | 879 | 16,000 | |
| 158- 160 GR. (J.S.P.) | 231 | 3.1 | 779 | 12,200 | 231 | 3.6 | 809 | 15,000 | |
| 148 GR. (LEAD W.C. TARGET) | 231 | 3.1 | 788 | 11,800 | 231 | 3.8 | 862 | 14,400 | |

NEVER EXCEED MAXIMUM LOADS.

(Source: Hodgdon Reloading Manual # 26)

.38 SPECIAL - WINCHESTER POWDERS

.38 SPECIAL + P

WINCHESTER

| CASE: WINCHESTER | | BARREL: 4" | | | PRIMER: WINCHESTER SP | | |
|----------------------------------|----------------|-------------------|------------|---------------|--------------------------|------------|--|
| POWDER | STARTING LOADS | | | MAXIMUM LOADS | | | |
| | GRS. | VEL. | PRESSURE | GRS. | VEL. | PRESSURE | |
| BULLET: 110 GR. WIN JHP | | DIA. .356" | | | C.O.L. 1.550" MAX | | |
| 231 | 5.3 | 935 | 14,700 PSI | 5.7 | 1015 | 17,600 PSI | |
| BULLET: 125 GR. WIN JHP | | DIA. .356" | | | C.O.L. 1.550" MAX | | |
| 231 | 4.8 | 840 | 14,100 PSI | 5.3 | 935 | 17,200 PSI | |
| BULLET: 140 GR. WIN JHP | | DIA. .356" | | | C.O.L. 1.550" MAX | | |
| 231 | 4.3 | 685 | 13,900 PSI | 4.8 | 785 | 17,200 PSI | |
| BULLET: 148 GR. WIN LHBWC | | DIA. .358" | | | C.O.L. 1.550" MAX | | |
| 231 | 2.9 | 690 | 12,400 PSI | 3.3 | 770 | 16,100 PSI | |
| WST | 2.5 | 680 | 13,000 PSI | 2.8 | 735 | 16,000 PSI | |
| BULLET: 158 GR. WIN JHP | | DIA. .356" | | | C.O.L. 1.550" MAX | | |
| 231 | 4.0 | 635 | 13,900 PSI | 4.4 | 720 | 17,200 PSI | |
| BULLET: 158 GR. WIN LSWC | | DIA. .358" | | | C.O.L. 1.550" MAX | | |
| 231 | 4.0 | 745 | 12,600 PSI | 4.7 | 860 | 17,100 PSI | |

NEVER EXCEED MAXIMUM LOADS.

.38 SPECIAL - VIHTAVUORI POWDERS

.38 Special

CIP max. dimensions in millimetres, SAAMI in inches

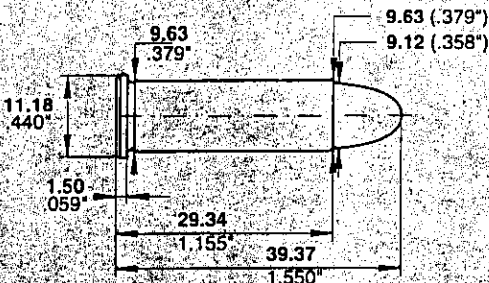

Country of origin: USA
Year of introduction: 1902
Max. bullet diameter: 9.12 mm (.358")
Max. cartridge length: 39.37 mm (1.550")
Max. shell length: 29.34 mm (1.155"), trim to 29.10 mm (1.145")
Max. CIP piezo pressure: 150 MPa (21750 psi)

The .38 Special, also known as the .38 Colt Special and the .38 S&W Special, was introduced by Smith & Wesson in 1902 for the S&W Military and Police Model revolver. Colt followed soon by introducing their version of the cartridge, which differs from the original only in the shape of the bullet nose. Today the .38 Special has widely replaced the .38 S&W Colt N.P. from service use and virtually all revolver manufacturers offer this chambering both for sporting and service applications. A number of good-quality lever-action carbines has been chambered for the .38 Special, too.

The .38 Special is widely considered as one of the best-balanced, all-round handgun cartridges ever developed. It is very accurate and is widely used for big bore handgun match shooting. It may be said that the .38 Special represents the same to a handgunner as the .308 Winchester is to the rifleman. The .38 Special can be used on everything from self-defence to plinking and target shooting, with excellent results.

The maximum loads listed in the following .38 Special reloading data represents SAAMI +P loads and should be used only in modern guns designed by the manufacturer for +P chamber pressure. These maximum loads must not be used in guns without +P-certification. For those firearms use starting loads as a maximum loads!

.38 SPECIAL - VIHTAVUORI POWDERS

.38 Special

TEST COMPONENTS:

Test barrel: 170 mm (6 1/2"), 1 in 18" twist, manufactured to meet CIP minimum dimensions.

Primers: Small Pistol

Cases: Sako, trim-to length 29.10 mm (1.145")

Reloading Data, English Units:

NOTE: THE LISTED MAXIMUM LOADS ARE SAAMI +P LOADS!

| Bullet | | | | Powder | Starting Load | | Maximum Load | | |
|--------------|--------|-----------|--------------|--------|---------------|----------------|--------------|----------------|----------------|
| Weight [grs] | Type | Mfg. | C.O.L. [in.] | Type | Weight [grs] | Velocity [fps] | Weight [grs] | Velocity [fps] | Pressure [psi] |
| 110 | HP/XTP | Homady | 1.437 | N320 | 5.7 | 1188 | 5.9 | 1230 | 18500 |
| | | | | N340 | 6.5 | 1191 | 6.7 | 1229 | 18500 |
| | | | | 3N37 | 7.7 | 1224 | 8.0 | 1266 | 18500 |
| | | | | N350 | 7.1 | 1227 | 7.4 | 1266 | 18500 |
| 124 | LSWC | Intercast | 1.437 | N320 | 4.8 | 1079 | 5.0 | 1119 | 18500 |
| | | | | N340 | 6.0 | 1125 | 6.2 | 1164 | 18500 |
| | | | | 3N37 | 6.6 | 1135 | 6.8 | 1170 | 18500 |
| | | | | N350 | 6.4 | 1152 | 6.6 | 1183 | 18500 |
| 125 | FP/XTP | Homady | 1.437 | N320 | 5.3 | 1043 | 5.4 | 1082 | 18500 |
| | | | | N340 | 6.2 | 1102 | 6.4 | 1140 | 18500 |
| | | | | 3N37 | 7.2 | 1115 | 7.3 | 1160 | 18500 |
| | | | | N350 | 7.0 | 1132 | 7.2 | 1178 | 18500 |
| 125 | FP | Rainier | 1.437 | N320 | 4.7 | 1017 | 5.0 | 1053 | 18500 |
| | | | | N340 | 5.7 | 1066 | 6.0 | 1106 | 18500 |
| | | | | N350 | 6.3 | 1070 | 6.6 | 1115 | 18500 |
| | | | | 3N37 | 6.6 | 1093 | 6.9 | 1140 | 18500 |

continues on the next page ...

INDICATES MAXIMUM LOAD - USE WITH CAUTION!
LOADS LESS THAN MINIMUM CHARGES SHOWN ARE NOT RECOMMENDED

.38 SPECIAL - VIHTAVUORI POWDERS

.38 Special

continues from the previous page ...

Reloading Data, English Units:

NOTE: THE LISTED MAXIMUM LOADS ARE SAAMI +P LOADS!

| Bullet | | | | Powder | Starting Load | | Maximum Load | | | | | | |
|-----------------|------|------------|-----------------|--------|-----------------|-------------------|-----------------|-------------------|-------------------|------|-----|------|-------|
| Weight [grs] | Type | Mfg. | C.O.L. [in.] | Type | Weight [grs] | Velocity [fps] | Weight [grs] | Velocity [fps] | Pressure [psi] | | | | |
| 140 | HP | Speer | 1.437 | N320 | 5.0 | 955 | 5.1 | 1003 | 18500 | | | | |
| | | | | N340 | 5.8 | 981 | 6.1 | 1030 | 18500 | | | | |
| | | | | 3N37 | 6.6 | 1010 | 6.9 | 1064 | 18500 | | | | |
| | | | | N350 | 6.4 | 1004 | 6.7 | 1053 | 18500 | | | | |
| 145 | LSWC | Inter cast | 1.476 | N320 | 4.1 | 938 | 4.4 | 971 | 18500 | | | | |
| | | | | N340 | 5.3 | 1033 | 5.6 | 1076 | 18500 | | | | |
| | | | | 3N37 | 5.6 | 1001 | 5.9 | 1039 | 18500 | | | | |
| | | | | N350 | 5.8 | 1043 | 6.2 | 1089 | 18500 | | | | |
| | | | | 146 | JHP | Speer | 1.378 | N340 | 5.0 | 922 | 5.2 | 963 | 18500 |
| | | | | | | | | 3N37 | 5.7 | 932 | 5.9 | 975 | 18500 |
| | | | | N350 | 5.6 | 932 | 5.7 | 971 | 18500 | | | | |
| | | | | 148 | LWC | Sako | 1.181 | N320 | 3.2 | 820 | 3.4 | 848 | 18500 |
| | | | | | | | | N330 | 3.6 | 840 | 3.7 | 875 | 18500 |
| | | | | N340 | 3.9 | 863 | 4.0 | 895 | 18500 | | | | |
| | | | | 158 | HP | Speer | 1.437 | N350 | 4.3 | 892 | 4.5 | 928 | 18500 |
| | | | | | | | | N320 | 4.2 | 794 | 4.4 | 843 | 18500 |
| | | | | N340 | 5.2 | 876 | 5.4 | 929 | 18500 | | | | |
| | | | | 158 | FP | Raimier | 1.476 | 3N37 | 6.1 | 915 | 6.4 | 957 | 18500 |
| | | | | | | | | N350 | 5.9 | 925 | 6.1 | 969 | 18500 |
| | | | | N320 | 4.3 | 843 | 4.6 | 885 | 18500 | | | | |
| | | | | 160 | LFN | Inter cast | 1.476 | N340 | 5.3 | 879 | 5.5 | 923 | 18500 |
| | | | | | | | | N350 | 5.9 | 922 | 6.1 | 963 | 18500 |
| | | | | 3N37 | 6.1 | 925 | 6.3 | 970 | 18500 | | | | |
| | | | | 160 | LFN | Inter cast | 1.476 | N340 | 5.4 | 1033 | 5.6 | 1070 | 18500 |
| | | | | | | | | 3N37 | 5.7 | 978 | 6.0 | 1021 | 18500 |
| | | | | N350 | 5.7 | 1014 | 5.9 | 1046 | 18500 | | | | |

INDICATES MAXIMUM LOAD - USE WITH CAUTION!
LOADS LESS THAN MINIMUM CHARGES SHOWN ARE NOT RECOMMENDED